



## Model 23A00-2 Flush Remote Temperature Sensor

### DESCRIPTION

The Model 23A00-2 is a flush mount temperature sensor that can be installed on your existing RC-Series Omnistat to monitor the temperature from a remote location. This will allow a customer to monitor the temperature of an area without a thermostat visible. The thermostat, or group of thermostats, could be in a different location offering the customer complete control of temperatures.

### INSTALLATION

1. Install Omnistat base in selected thermostat location and connect to heating/cooling equipment per manufacturer's instructions. Connect thermostat to base and confirm that everything operates correctly.
2. Disconnect the thermostat from the base. Locate the 3 solder holes on the lower right side of the thermostat PCA marked J4.
3. Using a clean soldering iron and safety glasses, carefully solder the supplied connector to the soldering holes as shown.
4. In selecting a place to mount the Remote Temperature Sensor, be sure to avoid an area where studs, plumbing, or electrical wiring may be located behind the wallboard. Hold the base of the plastic case against the wall. Trace around the perimeter of the plastic case with a pencil. Carefully cut along the pencil line. **DO NOT OVERSIZE THIS CUT-OUT!**
5. Run a 2 conductor, 22 gauge (or better) shielded cable from the Omnistat to the Remote Temperature Sensor location.
6. Connect the data wires of the shielded cable to the green data wires of the temperature sensor using the supplied wire splices.
7. Wrap the shield around the jacket of the cable and tape.
8. Insert the Remote Temperature Sensor base into the cutout in the wall.

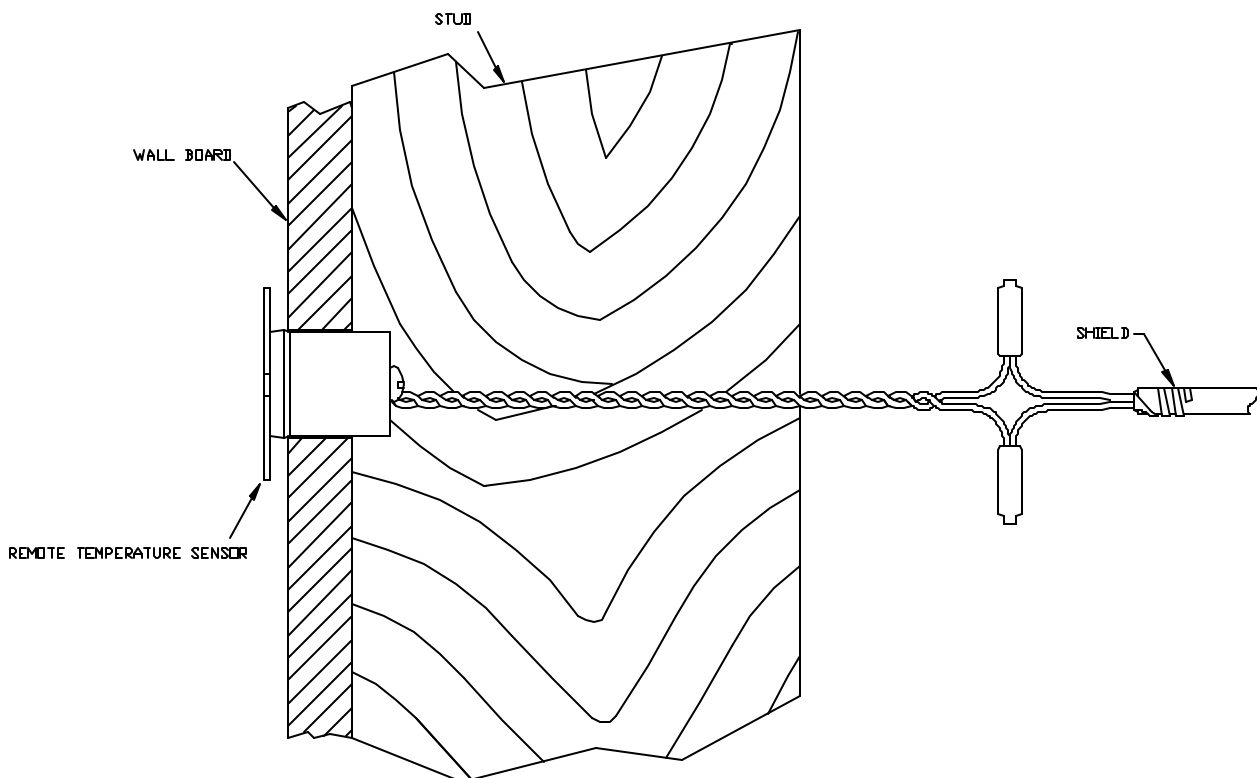

9. At the Omnistat location, connect the Black conductor of the supplied cable to the shield using the supplied wire splices. Connect the Green conductors of the supplied cable to the data wires using the supplied wire splices.

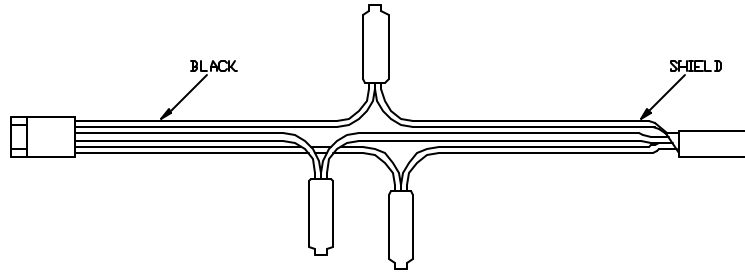

10. Carefully clip off the existing thermister (temperature sensing device) from the thermostat using a pair of wire cutters as shown.
11. Connect the supplied cable to the installed connector (J4) on the Omnistat.
12. Reconnect thermostat to the base and confirm that the thermostat is displaying the proper temperature.

