



Fire Alarm Control Panel MS-2 & MS-4

Fire Alarm System Limitations

An automatic fire alarm system—typically made up of smoke detectors, heat detectors, manual pull stations, audible warning devices, and a fire alarm control with remote notification capability—can provide early warning of a developing fire. Such a system, however, does not assure protection against property damage or loss of life resulting from a fire.

The Manufacturer recommends that smoke and/or heat detectors be located throughout a protected premise following the recommendations of the current edition of the National Fire Protection Association Standard 72 (NFPA 72), manufacturer's recommendations, State and local codes, and the recommendations contained in the Guide for Proper Use of System Smoke Detectors, which is made available at no charge to all installing dealers. A study by the Federal Emergency Management Agency (an agency of the United States government) indicated that smoke detectors may not go off in as many as 35% of all fires. While fire alarm systems are designed to provide early warning against fire, they do not guarantee warning or protection against fire. A fire alarm system may not provide timely or adequate warning, or simply may not function, for a variety of reasons:

Smoke detectors may not sense fire where smoke cannot reach the detectors such as in chimneys, in or behind walls, on roofs, or on the other side of closed doors. Smoke detectors also may not sense a fire on another level or floor of a building. A second-floor detector, for example, may not sense a first-floor or basement fire.

Particles of combustion or "smoke" from a developing fire may not reach the sensing chambers of smoke detectors because:

- Barriers such as closed or partially closed doors, walls, or chimneys may inhibit particle or smoke flow.
- Smoke particles may become "cold," stratify, and not reach the ceiling or upper walls where detectors are located.
- Smoke particles may be blown away from detectors by air outlets.
- Smoke particles may be drawn into air returns before reaching the detector.

The amount of "smoke" present may be insufficient to alarm smoke detectors. Smoke detectors are designed to alarm at various levels of smoke density. If such density levels are not created by a developing fire at the location of detectors, the detectors will not go into alarm.

Smoke detectors, even when working properly, have sensing limitations. Detectors that have photoelectronic sensing chambers tend to detect smoldering fires better than flaming fires, which have little visible smoke. Detectors that have ionizing-type sensing chambers tend to detect fast-flaming fires better than smoldering fires. Because fires develop in different ways and are often unpredictable in their growth, neither type of detector is necessarily best and a given type of detector may not provide adequate warning of a fire.

Smoke detectors cannot be expected to provide adequate warning of fires caused by arson, children playing with matches (especially in bedrooms), smoking in bed, and violent explosions (caused by escaping gas, improper storage of flammable materials, etc.).

While a fire alarm system may lower insurance rates, it is not a substitute for fire insurance!

Heat detectors do not sense particles of combustion and alarm only when heat on their sensors increases at a predetermined rate or reaches a predetermined level. Rate-of-rise heat detectors may be subject to reduced sensitivity over time. For this reason, the rate-of-rise feature of each detector should be tested at least once per year by a qualified fire protection specialist. *Heat detectors are designed to protect property, not life.*

IMPORTANT! Smoke detectors must be installed in the same room as the control panel and in rooms used by the system for the connection of alarm transmission wiring, communications, signaling, and/or power. If detectors are not so located, a developing fire may damage the alarm system, crippling its ability to report a fire.

Audible warning devices such as bells may not alert people if these devices are located on the other side of closed or partly open doors or are located on another floor of a building. Any warning device may fail to alert people with a disability or those who have recently consumed drugs, alcohol or medication. Please note that:

- Strobes can, under certain circumstances, cause seizures in people with conditions such as epilepsy.
- Studies have shown that certain people, even when they hear a fire alarm signal, do not respond or comprehend the meaning of the signal. It is the property owner's responsibility to conduct fire drills and other training exercise to make people aware of fire alarm signals and instruct them on the proper reaction to alarm signals.
- In rare instances, the sounding of a warning device can cause temporary or permanent hearing loss.

A fire alarm system will not operate without any electrical power. If AC power fails, the system will operate from standby batteries only for a specified time and only if the batteries have been properly maintained and replaced regularly.

Equipment used in the system may not be technically compatible with the control. It is essential to use only equipment listed for service with your control panel.

Telephone lines needed to transmit alarm signals from a premise to a central monitoring station may be out of service or temporarily disabled. For added protection against telephone line failure, backup radio transmission systems are recommended.

The most common cause of fire alarm malfunction is inadequate maintenance. To keep the entire fire alarm system in excellent working order, ongoing maintenance is required per the manufacturer's recommendations, and UL and NFPA standards. At a minimum, the requirements of Chapter 7 of NFPA 72 shall be followed. Environments with large amounts of dust, dirt or high air velocity require more frequent maintenance. A maintenance agreement should be arranged through the local manufacturer's representative. Maintenance should be scheduled monthly or as required by National and/or local fire codes and should be performed by authorized professional fire alarm installers only. Adequate written records of all inspections should be kept.

Installation Precautions

WARNING - Several different sources of power can be connected to the fire alarm control panel. Disconnect all sources of power before servicing. Control unit and associated equipment may be damaged by removing and/or inserting cards, modules, or interconnecting cables while the unit is energized. Do not attempt to install, service, or operate this unit until this manual is read and understood.

CAUTION - *System Reacceptance Test after Software Changes.* To ensure proper system operation, this product must be tested in accordance with NFPA 72 Chapter 7 after any programming operation or change in site-specific software. Reacceptance testing is required after any change, addition or deletion of system components, or after any modification, repair or adjustment to system hardware or wiring.

All components, circuits, system operations, or software functions known to be affected by a change must be 100% tested. In addition, to ensure that other operations are not inadvertently affected, at least 10% of initiating devices that are not directly affected by the change, up to a maximum of 50 devices, must also be tested and proper system operation verified.

This system meets NFPA requirements for operation at 0-49° C/32-120° F and at a relative humidity of 85% RH (non-condensing) at 30° C/86° F. However, the useful life of the system's standby batteries and the electronic components may be adversely affected by extreme temperature ranges and humidity. Therefore, it is recommended that this system and all peripherals be installed in an environment with a nominal room temperature of 15-27° C/60-80° F.

Verify that wire sizes are adequate for all initiating and indicating device loops. Most devices cannot tolerate more than a 10% I.R. drop from the specified device voltage.

Adherence to the following will aid in problem-free installation with long-term reliability:

Like all solid state electronic devices, this system may operate erratically or can be damaged when subjected to lightning-induced transients. Although no system is completely immune from lightning transients and interferences, proper grounding will reduce susceptibility. *Overhead or outside aerial wiring is not recommended, due to an increased susceptibility to nearby lightning strikes.* Consult with the Technical Services Department if any problems are anticipated or encountered.

Disconnect AC power and batteries prior to removing or inserting circuit boards. Failure to do so can damage circuits.

Remove all electronic assemblies prior to any drilling, filing, reaming, or punching of the enclosure. When possible, make all cable entries from the sides or rear. Before making modifications, verify that they will not interfere with battery, transformer, and printed circuit board location.

Do not tighten screw terminals more than 9 in-lbs. Over-tightening may damage threads, resulting in reduced terminal contact pressure and difficulty with screw terminal removal.

Though designed to last many years, system components can fail at any time. This system contains static-sensitive components. Always ground yourself with a proper wrist strap before handling any circuits so that static charges are removed from the body. Use static-suppressive packaging to protect electronic assemblies removed from the unit.

Follow the instructions in the installation, operating, and programming manuals. These instructions must be followed to avoid damage to the control panel and associated equipment. FACP operation and reliability depend upon proper installation by authorized personnel.

FCC Warning

WARNING: This equipment generates, uses, and can radiate radio frequency energy and if not installed and used in accordance with the instruction manual, may cause interference to radio communications. It has been tested and found to comply with the limits for class A computing device pursuant to Subpart B of Part 15 of FCC Rules, which is designed to provide reasonable protection against such interference when operated in a commercial environment. Operation of this equipment in a residential area is likely to cause interference, in which case the user will be required to correct the interference at his own expense.

Canadian Requirements

This digital apparatus does not exceed the Class A limits for radiation noise emissions from digital apparatus set out in the Radio Interference Regulations of the Canadian Department of Communications.

Le présent appareil numérique n'émet pas de bruits radioélectriques dépassant les limites applicables aux appareils numériques de la classe A prescrites dans le Règlement sur le brouillage radioélectrique édicté par le ministère des Communications du Canada.

Notes

Table of Contents

SECTION 1: Product Description	10
1.1: Product Features	10
1.2: Specifications	12
1.3: Controls and Indicators	13
1.4: Circuits	14
1.5: Components	14
1.6: Optional Modules and Accessories	15
SECTION 2: Installation	17
2.1: Backbox Mounting	17
2.2: Operating Power	19
2.3: Input Circuits	20
2.4: Output Circuits	22
2.4.1: Notification Appliance Circuits	22
2.4.2: DC Power Output Connections	23
2.4.3: Relays	23
2.5: Power-limited Wiring Requirements	24
2.6: Installation of Optional Modules	25
2.6.1: CAC-4 Class A Converter Module (MS-4 only)	25
2.6.1.1 Installation	25
2.6.1.2 Wiring NACs and IDCs for Class A	26
2.6.2: 4XTMF, 4XLMF and 4XZMF Option Modules (MS-4 only)	27
2.6.2.1 4XTMF Transmitter Module Installation (MS-4 only)	28
2.6.2.2 4XZMF Zone Relay Module (MS-4 only)	29
2.6.2.3 4XLMF LED Interface Module (MS-4 only)	30
SECTION 3: Program Options via DIP Switch	31
3.1: DIP Switch Settings	32
3.1.1: SW1 DIP Switch Settings	34
3.1.1.1 Silence Inhibit	34
3.1.1.2 Auto-silence	34
3.1.1.3 Temporal Coding	34
3.1.1.4 Selective Silence	34
3.1.1.5 Trouble Reminder	34
3.1.1.6 AC Trouble Delay	34
3.1.1.7 Autoresettable Supervisory	34
3.1.1.8 IDC Combination Circuit	34
3.1.2: SW2 DIP Switch Settings	35
3.1.2.1 IDC1 Verification (MS-4 only)	35
3.1.2.2 IDC1 Supervisory (MS-4 only)	35
3.1.2.3 IDC1 Verification for MS-2 or IDC2 Verification for MS-4	35
3.1.2.4 IDC1 Supervisory for MS-2 or IDC2 Supervisory for MS-4	35
3.1.2.5 IDC2 Verification for MS-2 or IDC3 Verification for MS-4	36
3.1.2.6 IDC2 Supervisory for MS-2 or IDC3 Supervisory for MS-4	36
3.1.2.7 IDC4 Verification (MS-4 only)	36
3.1.2.8 IDC4 Supervisory (MS-4 only)	36
3.1.3: SW3 DIP Switch Settings	36
3.1.3.1 NAC1 Nonsilenceable	36
3.1.3.2 NAC1 Disable	36
3.1.3.3 NAC2 Nonsilenceable (MS-4 only)	36
3.1.3.4 NAC2 Disable (MS-4 only)	36
3.1.3.5 Strobe Synchronization	37
3.1.3.6 Nonsilenceable Waterflow for Combination Circuit	37
3.1.3.7 Spares	37
SECTION 4: Operating Instructions	38

Table of Contents

4.1: Switch Functions in Normal Mode.....38

 4.1.1: ACK - Acknowledge.....38

 4.1.2: Silence.....38

 4.1.3: Zone Enable/Disable.....38

 4.1.4: Reset/(Lamp Test).....38

 4.1.5: Walktest.....39

4.2: Walktest.....39

4.3: Status LEDs.....40

4.4: Operation.....41

 4.4.1: Fire Alarm Response.....42

 4.4.2: Fire Alarm Restoral.....42

 4.4.3: System Supervisory Condition Response.....42

 4.4.4: System Supervisory Restoral Response.....42

 4.4.5: Trouble Condition Response.....43

 4.4.6: Trouble Condition Restoral.....43

SECTION 5: Power Supply Calculations44

 5.1: Overview.....44

 5.2: Calculating the AC Branch Circuit.....44

 5.3: Calculating the System Current Draw.....45

 5.3.1: Overview.....45

 5.3.2: How to Use Table 5-3 on page 46 to Calculate System Current Draw.....45

 5.4: Calculating the Battery Size.....47

 5.4.1: NFPA Battery Requirements.....47

 5.4.2: Selecting and Locating Batteries.....47

It is imperative that the installer understand the requirements of the Authority Having Jurisdiction (AHJ) and be familiar with the standards set forth by the following regulatory agencies:

- Underwriters Laboratories Standards
- NFPA 72 National Fire Alarm Code

Before proceeding, the installer should be familiar with the following documents.



NFPA Standards

This Fire Alarm Control Panel complies with the following NFPA Standards:

NFPA 72 National Fire Alarm Code for Local Fire Alarm Systems and Remote Station Fire Alarm Systems (requires an optional Remote Station Output Module)



Underwriters Laboratories Documents for Reference:

- UL 38 Manually Actuated Signaling Boxes
- UL 217 Smoke Detectors, Single and Multiple Station
- UL 228 Door Closers–Holders for Fire Protective Signaling Systems
- UL 268 Smoke Detectors for Fire Protective Signaling Systems
- UL 268A Smoke Detectors for Duct Applications
- UL 346 Waterflow Indicators for Fire Protective Signaling Systems
- UL 464 Audible Signaling Appliances
- UL 521 Heat Detectors for Fire Protective Signaling Systems
- UL 864 Standard for Control Units for Fire Protective Signaling Systems
- UL 1481 Power Supplies for Fire Protective Signaling Systems
- UL 1638 Visual Signaling Appliances
- UL 1971 Signaling Devices for Hearing Impaired

Other:

- NEC Article 250 Grounding
- NEC Article 300 Wiring Methods
- NEC Article 760 Fire Protective Signaling Systems
- Applicable Local and State Building Codes
- Requirements of the Local Authority Having Jurisdiction (LAHJ)

Fire•Lite Documents

- | | |
|--|-----------------|
| Fire•Lite Device Compatibility Document | Document #15384 |
| 411 Digital Alarm Communicator/Transmitter | Document #50921 |
| 411UD Digital Alarm Communicator/Transmitter | Document #50759 |

MS-2 Main Circuit Board

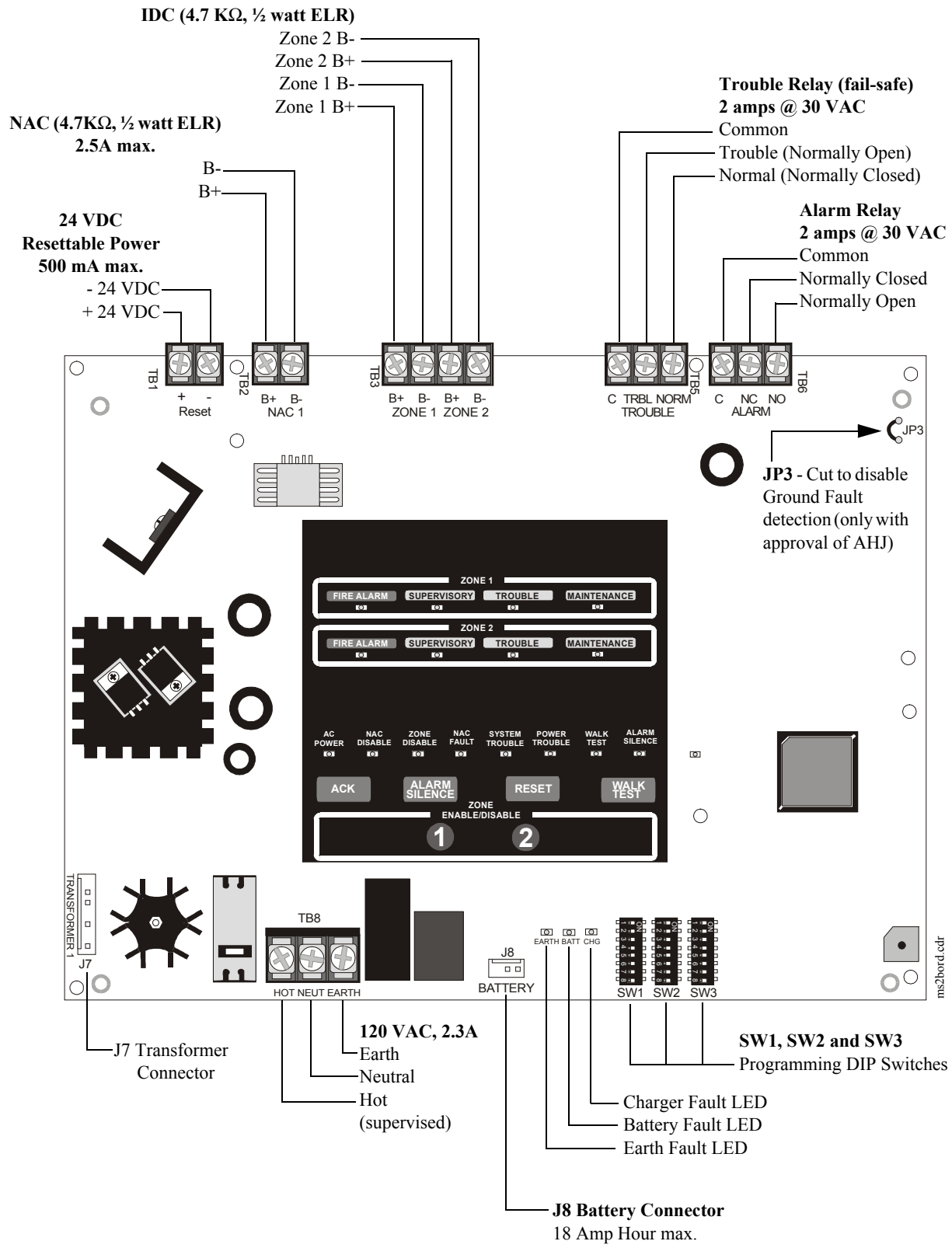

SECTION 1 Product Description

The MS-2 is a two zone FACP (Fire Alarm Control Panel) and the MS-4 is a four zone FACP. The information in this manual refers to both the MS-2 and MS-4 unless otherwise specified. These control panels provide reliable fire signaling protection for small to medium sized commercial, industrial and institutional buildings. The FACP is compatible with System Sensor's I³ detectors which are microprocessor-based conventional smoke detectors that can transmit a maintenance trouble signal to the FACP indicating the need for cleaning and a supervisory 'freeze' signal when the ambient temperature falls below the detector rating (refer to System Sensor's I³ Installation and Maintenance Instructions document I56-1800-00 for device specifications). In addition, the control panel is compatible with conventional input devices such as two-wire smoke detectors, four-wire smoke detectors, pull stations, waterflow devices, tamper switches and other normally-open contact devices. Refer to Fire•Lite Device Compatibility Document for a complete listing of compatible devices.

Outputs include one NAC (Notification Appliance Circuit) on the MS-2 and two NACs on the MS-4. Each FACP has a Form-C Alarm and Trouble relay and 24 VDC resettable power. In addition, the MS-4 has a Form-C Supervisory relay and a nonresettable power output. The FACP supervises wiring, AC voltage and battery level.

Activation of a compatible smoke detector or any normally-open fire alarm initiating device will activate audible and visual signaling devices, illuminate an indicating LED, sound the piezo sounder at the FACP, activate the FACP alarm relay and operate an optional module used to notify a remote station or initiate a auxiliary control function.

1.1 Product Features

- Style B (Class B) IDC (Initiating Device Circuit)
 - ✓ one zone programmable for combination supervisory and waterflow
 - ✓ MS-2 - two IDCs
 - ✓ MS-4 - four IDCs
- Style Y (Class B) NAC (Notification Appliance Circuit)
 - ✓ MS-2- one NAC
 - ✓ MS-4 - two NACs
- Form-C Alarm Relay
- Form-C Trouble Relay
- Form-C Supervisory Relay (MS-4 only)
- 3.0 amps total system current standard for MS-2 and MS-4
- 6.0 amps total system current available for MS-4 with optional second transformer
- Optional Dress Panel DP-MS2/4
- Optional Trim Ring P/N: TR-1-R for semi-flush mounting the cabinet
- Control Buttons
 - ✓ ACK (Acknowledge)
 - ✓ Alarm Silence
 - ✓ Reset
 - ✓ Walktest
 - ✓ Zone Enable/Disable (one per zone)

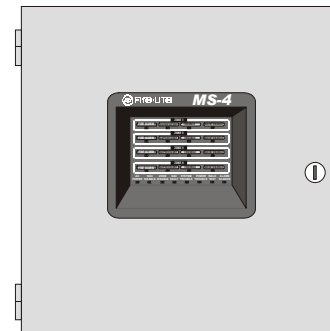

- LED Indicators
 - ✓ Fire Alarm (one per zone)
 - ✓ Supervisory (one per zone)
 - ✓ Trouble (one per zone)
 - ✓ Maintenance (one per zone)
 - ✓ AC Power
 - ✓ NAC Disable
 - ✓ Zone Disable
 - ✓ NAC Fault
 - ✓ System Trouble
 - ✓ Power Trouble
 - ✓ Walktest
 - ✓ Alarm Silence
 - ✓ Earth Fault (on circuit board)
 - ✓ Battery Fault (on circuit board)
 - ✓ Charger Fault (on circuit board)
- Piezo sounder for alarm, trouble and supervisory
- 24 volt operation
- Low AC voltage sense
- Alarm Verification
- NACs Programmable for:
 - ✓ Silence Inhibit
 - ✓ Auto-Silence
 - ✓ Strobe Synchronization
 - ✓ Selective Silence (horn-strobe mute)
 - ✓ Temporal or Steady Signal
 - ✓ Silenceable or Nonsilenceable
- Automatic battery trickle charger
- Silent or audible walktest capabilities
- Optional NAC Class A converter module (MS-4 only)
- Optional 4XTMF Transmitter Module (MS-4 only)
- Optional 4XZMF Zone Relay Module (MS-4 only)
- Optional 4XLMF Module for RZA-4XF Remote LED Annunciator (MS-4 only)

1.2 Specifications

AC Power - TB8

120 VAC, 50/60 Hz, 2.3 amps

Wire size: minimum #14 AWG (2.0 mm²) with 600V insulation

Battery (sealed lead acid only) - J8

Maximum Charging Circuit - Normal Flat Charge: 27.6 VDC @ 0.8 amp

Maximum Charger Capacity: 18 Amp Hour battery (two 7 Amp Hour batteries can be housed in the FACP cabinet. Larger batteries require a separate battery box such as the Fire•Lite BB-17F)

Initiating Device Circuits - TB3

Alarm Zones 1 & 2 (MS-2 and MS-4)

Alarm Zones 3 & 4 (MS-4 only)

Power-limited circuitry

Operation: All zones Style B (Class B)

Normal Operating Voltage: Nominal 20 VDC

Alarm Current: 15 mA minimum

Short Circuit Current: 40 mA maximum

Maximum Loop Resistance: 100 ohms

End-of-Line Resistor: 4.7K Ω , ½ watt (Part #71252)

Standby Current: 4 mA

Refer to Fire•Lite Device Compatibility Document for listed compatible devices

Notification Appliance Circuit(s) - TB2¹

One NAC on MS-2, two NACs on MS-4

Operation: Style Y (Class B)

Power-limited Circuitry

Normal Operating Voltage: Nominal 24 VDC

Maximum Signaling Current: 2.5 amps total with standard transformer. 5.0 amps total (2.5 amp maximum per NAC) with optional transformer on MS-4 only

End-of-Line Resistor: 4.7K Ω , ½ watt (Part #71252)

Refer to Fire•Lite Device Compatibility Document for compatible listed devices

Form-C Relays

Trouble Relay TB5 (fail-safe)

Alarm Relay TB6

Supervisory Relay TB7 (MS-4 only)

Relay Contact Ratings: 2 amps @ 30 VAC (resistive)

Resettable Power - TB1

Operating Voltage: Nominal 24 VDC

Maximum Available Current: 500 mA - appropriate for powering 4-wire smoke detectors (see note 1)

Power-limited Circuitry

Refer to Fire•Lite Device Compatibility Document for compatible listed devices

Nonresettable Power - TB1 (MS-4 only)

Operating Voltage: Nominal 24 VDC

Maximum Available Current: 500 mA (see note 1)

Power-limited Circuitry

Refer to Fire•Lite Device Compatibility Document for compatible listed devices

-
1. Total current for resettable power and one Notification Appliance Circuit must not exceed 3.0 amps for the MS-2. Total current for nonresettable power, resettable power and two Notification Appliance Circuits must not exceed 6.0 amps for the MS-4 (requires optional second transformer)

1.3 Controls and Indicators

Front Panel Membrane Buttons

- Acknowledge
- Alarm Silence
- Reset
- Walktest
- Zone Enable/Disable - Zone 1
- Zone Enable/Disable - Zone 2
- Zone Enable/Disable - Zone 3 (MS-4 only)
- Zone Enable/Disable - Zone 4 (MS-4 only)

LED Indicators

- Fire Alarm Zone 1 - red LED
- Fire Alarm Zone 2 - red LED
- Fire Alarm Zone 3 - red LED (MS-4 only)
- Fire Alarm Zone 4 - red LED (MS-4 only)
- Supervisory Zone 1 - yellow LED
- Supervisory Zone 2 - yellow LED
- Supervisory Zone 3 - yellow LED (MS-4 only)
- Supervisory Zone 4 - yellow LED (MS-4 only)
- Trouble Zone 1 - yellow LED
- Trouble Zone 2 - yellow LED
- Trouble Zone 3 - yellow LED (MS-4 only)
- Trouble Zone 4 - yellow LED (MS-4 only)
- Maintenance Zone 1 - yellow LED
- Maintenance Zone 2 - yellow LED
- Maintenance Zone 3 - yellow LED (MS-4 only)
- Maintenance Zone 4 - yellow LED (MS-4 only)
- AC Power - green LED
- NAC Disable - yellow LED
- Zone Disable - yellow LED
- NAC Fault - yellow LED
- System Trouble - yellow LED
- Power Trouble - yellow LED
- Walktest - yellow LED
- Alarm Silence - yellow LED
- Earth Fault - yellow LED (on main circuit board)
- Battery Fault - yellow LED (on main circuit board)
- Charger Fault - yellow LED (on main circuit board)

Local Piezo Sounder

A piezo sounder provides separate and distinct sounds for alarm, trouble, maintenance and supervisory conditions as follows:

- Alarm - on steady
- Trouble - pulse 1 second on and 1 second off
- Maintenance - pulse ½ second on and ½ second off
- Supervisory - pulse ½ second on and ½ second off

1.4 Circuits**Input Circuits**

Two input IDCs (Initiating Device Circuits) on the MS-2 and four IDCs on the MS-4 provide Style B (Class B) configurations. All IDCs accept I³ detectors as well as conventional two-wire smoke detectors, four-wire smoke detectors and normally-open contact devices.

Output Circuits

- 24 VDC resettable power output - 500 mA
- 24 VDC nonresettable power output (MS-4 only) - 500 mA
- 24 volt battery charger (up to 18 Amp Hour batteries)

Notification Appliance Circuits

One NAC (Notification Appliance Circuit) Style Y (Class B) on the MS-2
Two NACs Style Y (Class B) on the MS-4

Relays

Alarm Relay
Trouble Relay (fail-safe)
Supervisory Relay (MS 4 only)
Form-C contacts rated 2.0 amps @ 30 VAC (resistive)

1.5 Components**Main Circuit Board**

The main circuit board contains the system's CPU, power supply, other primary components and wiring interface connectors. Optional modules plug in and are mounted to the MS-4 main circuit board only.

Cabinet

The cabinet is red and the backbox measures 14.5" (36.8 cm) x 15.218" (38.65 cm) x 2.875" (7.3 cm) and provides space for two batteries (up to 7 Amp Hours). Also available is an optional dress panel which mounts inside the cabinet.

Transformer Assembly

One 100VA transformer is provided standard with the FACP. An optional second 100VA transformer is available for the MS-4 to provide maximum accessory power.

Batteries

The cabinet provides space for two 7 Amp Hour batteries (larger batteries up to 18 Amp Hour, require use of a UL listed battery box such as the Fire•Lite BB-17F). Batteries must be ordered separately.

1.6 Optional Modules and Accessories

CAC-4 Class A Converter Module (MS-4 only)

The CAC-4 Module can be used to convert the Style B (Class B) Initiating Device Circuits to Style D (Class A) and Style Y (Class B) Notification Appliance Circuits to Style Z (Class A). The module connects to J1 on the MS-4 main circuit board.

4XTMF Transmitter Module (MS-4 only)

The 4XTMF provides a supervised output for local energy municipal box transmitter and alarm and trouble reverse polarity. It includes a disable switch and disable trouble LED. A module jumper option allows the reverse polarity circuit to open with a system trouble condition if no alarm condition exists. The 4XTMF mounts to the MS-4 main circuit board, occupying one of the two sets of option module connectors.

4XLMF LED Interface Module (MS-4 only)

The LED Interface Module supports the RZA-4XF Remote Annunciator module. Annunciator wiring is supervised for open conditions by this module. The 4XLMF mounts to the MS-4 main circuit board option module connectors J3 and J5 only.

RZA-4XF Remote Annunciator (MS-4 only)

The Remote Annunciator mounts on a standard single-gang electrical box and provides LED indication of the following:

- Alarm Zone 1 (red LED)
- Alarm Zone 2 (red LED)
- Alarm Zone 3 (red LED)
- Alarm Zone 4 (red LED)
- System Trouble (yellow LED)

A Local Trouble Sounder and Silence Switch are also provided. All LED wiring is supervised for open conditions. Any open condition will cause the System Trouble LED to illuminate. Slide-in paper labels permit an easy change of zone information.

Note: The RZA-4XF Remote Annunciator requires the use of the LED Interface Module (4XLMF).

4XZMF Zone Relay Module (MS-4 only)

The Zone Relay Module provides Form-C relay contacts for the following:

- Alarm Zone 1
- Alarm Zone 2
- Alarm Zone 3
- Alarm Zone 4
- System Alarm
- System Trouble

As a jumper option, the first four relays described above can be made silenceable. The 4XZMF mounts to the MS-4 main circuit board, occupying one of the two sets of option module connectors.

Dress Panel DP-MS2/4

A dress panel DP-MS2/4 is available as an option. The dress panel restricts access to the system wiring while allowing access to the membrane switch panel.

Battery Box

The Fire•Lite BB-17F battery box may be used to house two batteries greater than 7 Amp Hour to a maximum of 18 Amp Hour. The battery box mounts directly below the control panel cabinet, centered to the main circuit board. The BB-17F is red and is provided with knockouts.

411 and 411UD Digital Alarm Communicator/Transmitter

The three input/channel 411 and the four input/channel 411UD are dual line, digital alarm communicator/transmitters which can be used as slave communicators with the MS-4 FACP. The inputs/channels are compatible with normally open relay contacts, require ELRs (End-of-Line Resistors), are supervised and are fully programmable. The communicators interface with the public switched telephone network and are compatible with most central station receivers. Power supplied must be 12 or 24 volts, filtered and nonresettable. The communicators are mounted in a small metal enclosure, providing a variety of mounting options. Refer to the 411 or 411UD manual for additional information.

SECTION 2

Installation

The cabinet can be surface mounted or semi-flush mounted using the optional Trim Ring P/N: **TR-1-R**. The door is removable during the installation period by opening and lifting it off the hinges. The cabinet mounts using two key slots at the top of the backbox and two additional 0.250" diameter holes located at the bottom.

Carefully unpack the system and check for shipping damage. Select a location for the cabinet that is in a clean, dry, vibration-free area where extreme temperatures are not encountered. The area should be readily accessible with sufficient room to easily install and maintain the control panel. Locate the top of the cabinet approximately five feet above the floor with the hinge mounting on the left.

Determine the number of conductors required for the devices to be installed and determine the appropriate knockouts. All wiring must be in accordance with the National and/or Local codes for fire alarm systems and power supplies.

2.1 Backbox Mounting

1. Mark and predrill holes for the top two keyhole mounting bolts
2. Install two upper fasteners in the wall with the screw heads protruding approximately 1/4"
3. Using the upper keyholes, mount the backbox over the two screws
4. Mark the lower two holes, remove the backbox from the wall and drill the mounting holes
5. Mount the backbox, install the remaining fasteners and tighten all screws

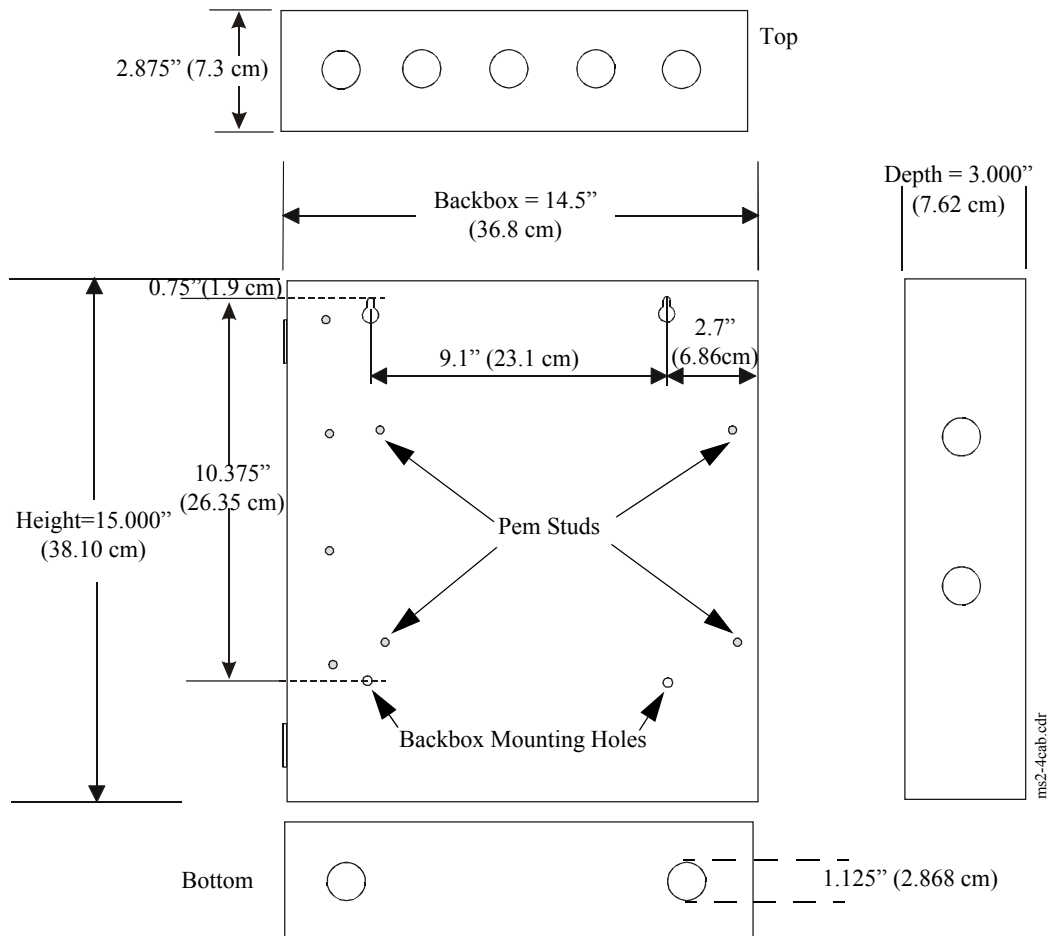

Figure 2.1 Backbox Mounting Dimensions

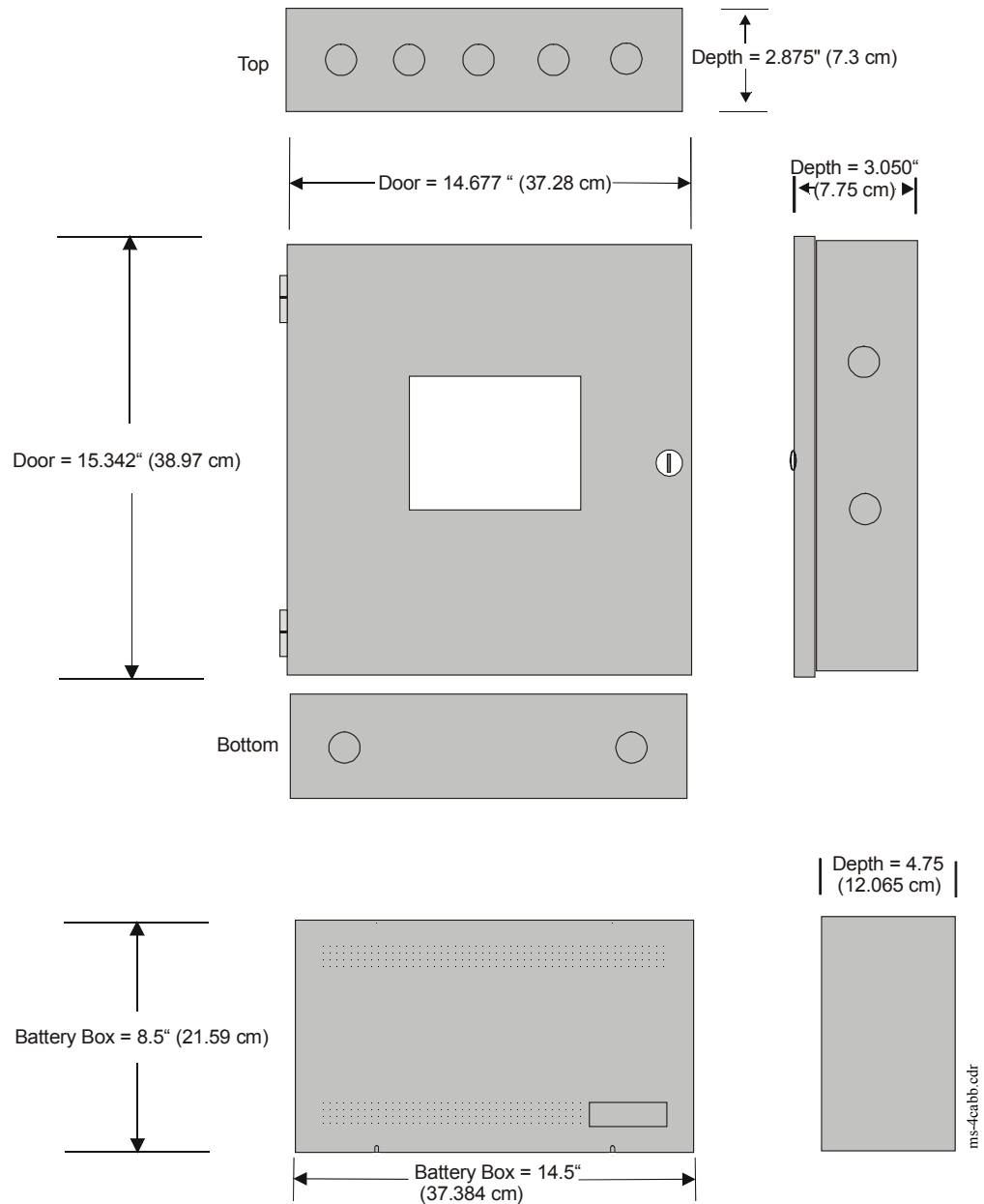

Figure 2.2 Backbox and Battery Box

When batteries larger than 7 Amp Hour, up to 18 Amp Hour, are being used, the BB-17F battery box (or UL listed equivalent) must be installed. To install the BB-17F:

1. Mount the FACP cabinet to the wall
2. Remove knockouts on the bottom of the FACP cabinet and top of the BB-17F
3. Using conduit, hang the BB-17F from the FACP cabinet making sure there is at least ½" of clearance between the two cabinets
4. Anchor the BB-17F to the wall

2.2 Operating Power



WARNING: Several different sources of power can be connected to this panel. Disconnect all sources of power before servicing. The panel and associated equipment may be damaged by removing and/or inserting cards, modules or interconnecting cables while this unit is energized.

Primary Power Source (AC) and Earth Ground Connections

AC power connections are made inside the control panel cabinet. The primary power source for the panel is 120 VAC, 50/60 Hz, 2.3 amps. Run a pair of wires (with ground conductor) from the protected premises main breaker box to TB8 of the main circuit board. As per the National Electrical Code, use 14 AWG (2.00 mm², 1.6 mm O.D.) or heavier gauge wire with 600V insulation. No other equipment may be connected to this circuit. In addition, this circuit must be provided with overcurrent protection and may not contain any power disconnect devices. A separate Earth Ground connection must be made to ensure proper panel operation and lightning and transient protection. Connect the Earth Ground wire [minimum 14 AWG (2.00 mm²)] to the transformer mounting stud. *Do not use conduit for the Earth Ground connection since this does not provide reliable protection.*

Secondary Power Source (Batteries)

Observe polarity when connecting the battery. Connect the battery cable to J8 on the main circuit board using the plug-in connector and cable provided. The battery charger is current-limited and capable of charging sealed lead acid batteries. The charger shuts off when the system is in alarm.



WARNING: Battery contains sulfuric acid which can cause severe burns to the skin and eyes and can destroy fabrics. If contact is made with sulfuric acid, immediately flush the skin or eyes with water for 15 minutes and seek immediate medical attention.

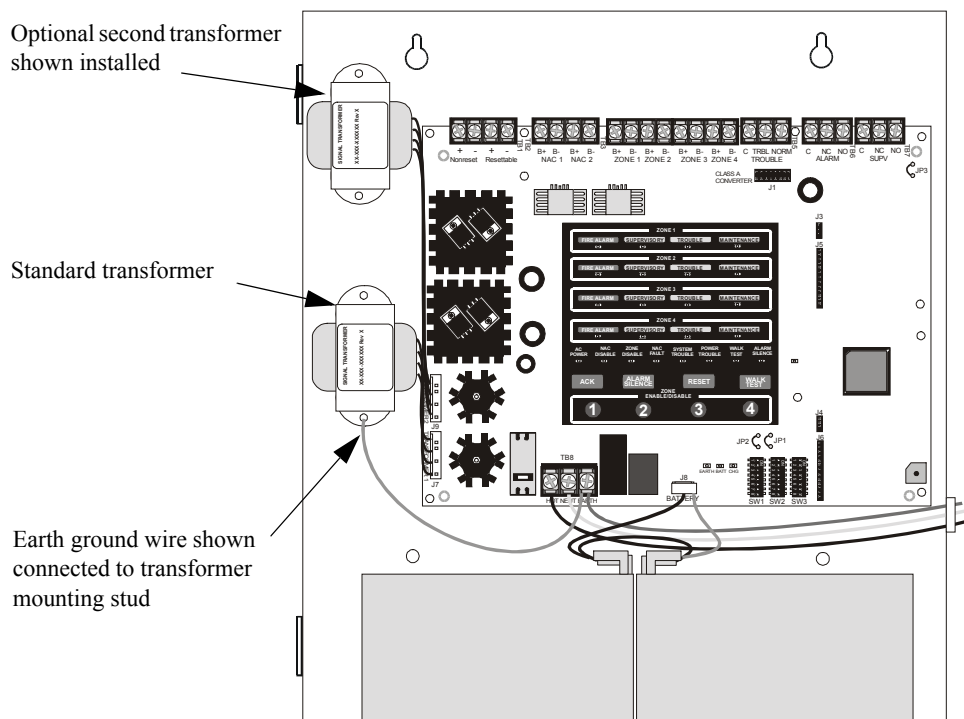

Figure 2.3 Operating Power Connections

2.3 Input Circuits

The MS-2 has two IDCs (Initiating Device Circuits) and the MS-4 has four IDCs. Each circuit is compatible with System Sensor's I³ smoke detectors which generate a maintenance signal when the detector becomes dirty and a separate supervisory 'freeze' signal when ambient temperature falls below the detector rating. The maximum loop resistance limit for each IDC is 100 ohms. The field wiring for each zone is supervised for opens, shorts and ground faults. All conditions are visually and audibly annunciated.

Each circuit is configured for Style B (Class B) operation and will accept I³ smoke detectors, any normally-open contact devices as well as conventional 2-wire or 4-wire, 24 VDC smoke detectors. In addition, Zone 1 (IDC 1) on the MS-2 and Zone 2 (IDC 2) on the MS-4 can be programmed as combination supervisory and waterflow zones. Refer to the Fire•Lite Device Compatibility Document for a list of compatible devices.

MS-4 Initiating Device Circuits can be converted to Style D (Class A) by installing the optional Class A Converter module. Refer to "CAC-4 Class A Converter Module (MS-4 only)" on page 25.

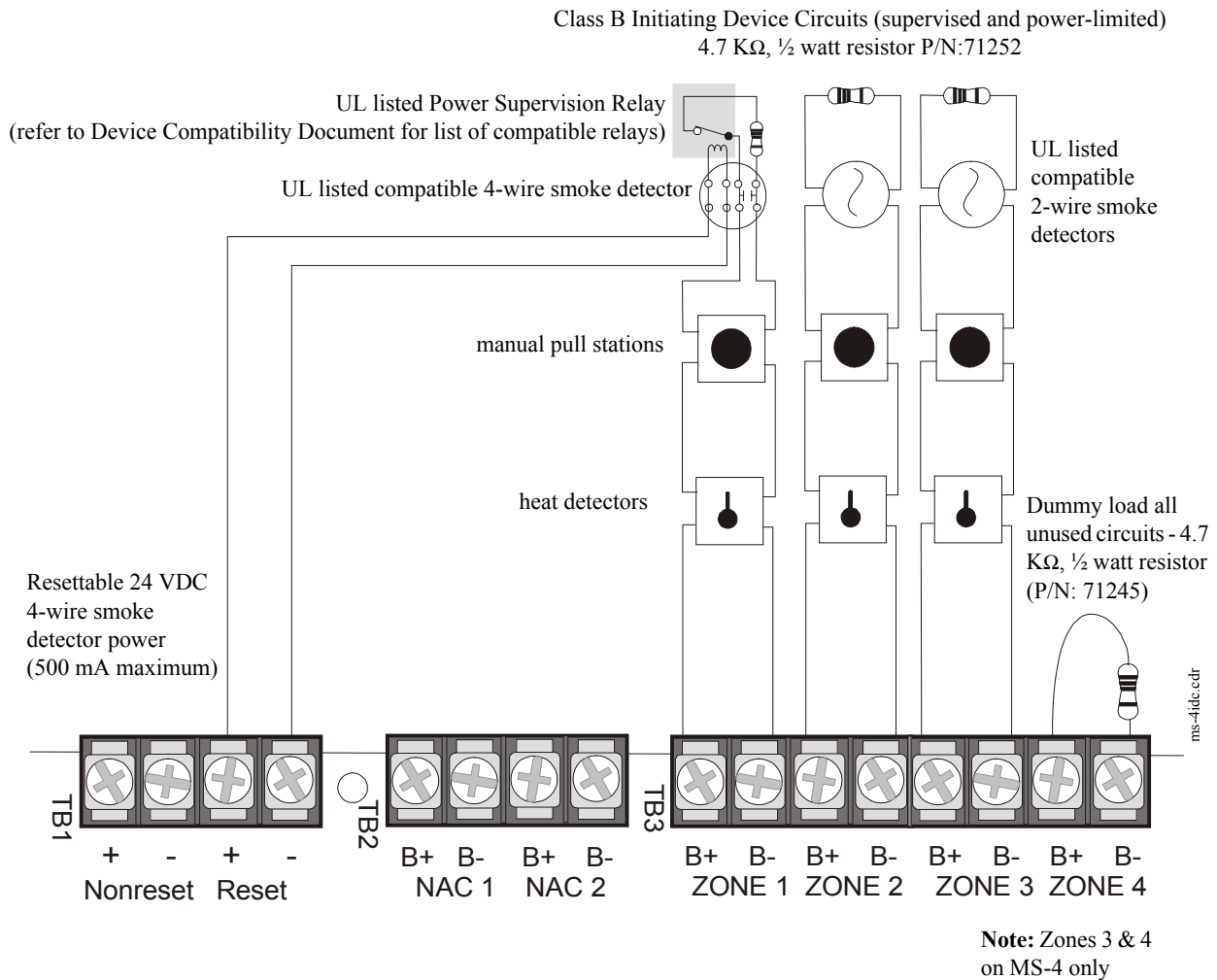

Figure 2.4 IDC Connections

Combination Waterflow/Supervisory Zone

A combination Waterflow/Supervisory circuit allows an FACP to distinguish between an Alarm switch (waterflow device) and a Supervisory switch (tamper) installed on the same circuit. The following figure illustrates the wiring of Zone 2 as a Style B (Class B) Waterflow/Supervisory circuit. Note that only Zone 1 on the MS-2 and Zone 2 on the MS-4 can be configured in this manner.

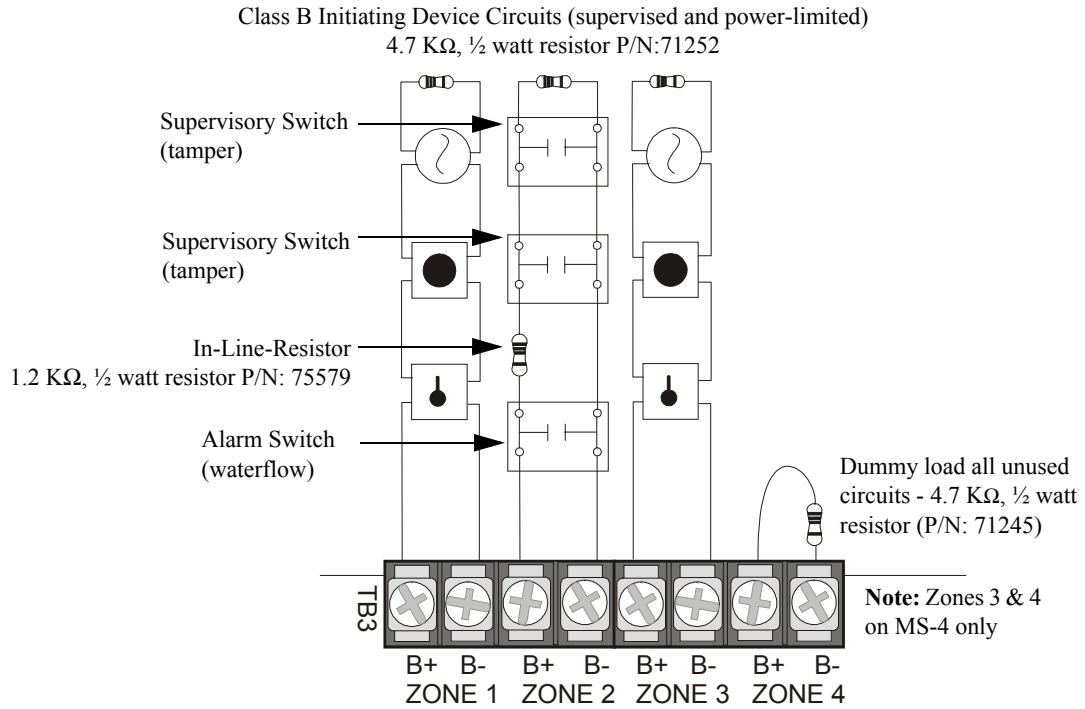

Figure 2.5 Style B Combination Circuit on Zone 2 of the MS-4

Requirements for the Combination Waterflow/Supervisory circuit are as follows:

- ✓ The Waterflow Alarm Switch(es) must connect to the FACP Initiating Device Circuit before the In-Line Resistor as shown in Figure 2.5
- ✓ The Waterflow Supervisory Switch(es) must connect to the FACP Initiating Device Circuit after the In-Line Resistor as shown in Figure 2.5
- ✓ Program the FACP Initiating Device Circuit #1 on the MS-2 or Circuit #2 on the MS-4 as a Combination circuit by placing SW1 DIP switch 8 to the ON position as described in "SW1 DIP Switch Settings" on page 34
- ✓ Waterflow Alarm Switch activation causes the panel to latch into alarm until the alarm condition is cleared and the FACP is reset
- ✓ Supervisory Switch activation causes the panel to track the supervisory condition, that is, the panel will clear when the supervisory condition is cleared (if FACP is programmed for Autoresettable Supervisory)

2.4 Output Circuits

2.4.1 Notification Appliance Circuits

The MS-2 provides one Style Y (Class B) NAC (Notification Appliance Circuit) while the MS-4 provides two Style Y (Class B) NACs. Each circuit is capable of providing a maximum of 2.5 amps of current. Total current drawn from these as well as other DC power outputs cannot exceed 3.0 amps for the MS-2 or 6.0 amps for the MS-4 with the optional second transformer installed (refer to battery calculations section). Each circuit is supervised and power-limited. Refer to the Fire•Lite Device Compatibility Document for a listing of compatible notification appliances.

The MS-4 NACs can be converted to Style Z (Class A) by installing the optional Class A Converter module. Refer to "CAC-4 Class A Converter Module (MS-4 only)" on page 25.

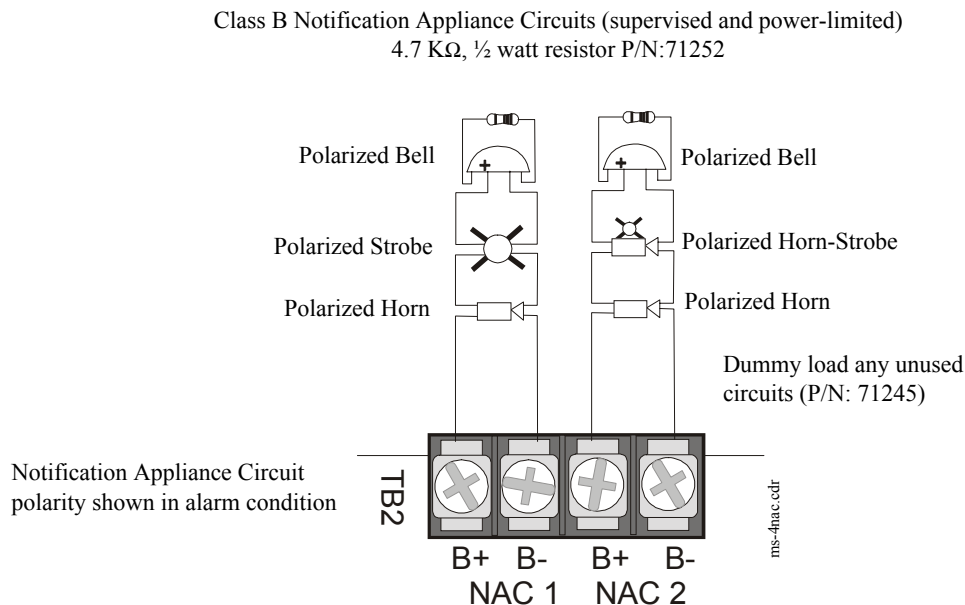

Figure 2.6 NAC Connections

2.4.2 DC Power Output Connections

Resettable 24 VDC power is available on both the MS-2 and MS-4 control panels. Nonresettable 24 VDC power is available only on the MS-4.

Nonresettable Power (500 mA) - MS-4 Only
24 VDC filtered, nonresettable power can be obtained from these terminals (power-limited)

4-Wire Smoke Detector Power (500 mA)
24 VDC filtered, resettable power for 4-wire smoke detectors can be obtained from these terminals (power-limited)

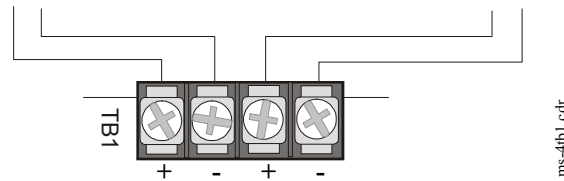

Figure 2.7 Auxiliary Power

2.4.3 Relays

The MS-2 and MS-4 control panels provide an alarm and fail-safe trouble relay and the MS-4 also provides a supervisory relay. Each Form-C relay is rated for 2 amps @ 30VAC (resistive).

Note that relay connections may be power-limited or nonpower-limited, provided that 0.25" minimum spacing is maintained between conductors of power-limited and nonpower-limited circuits.

Note: Relay contacts are shown with power applied to the panel and no active troubles, alarms or supervisories. The Trouble Relay is a fail-safe relay which will transfer on any trouble or total power failure.

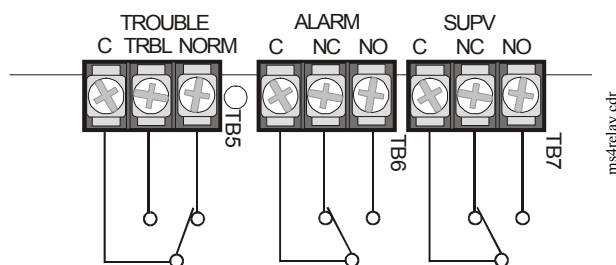

Figure 2.8 Relay Terminals

2.5 Power-limited Wiring Requirements

Power-limited and nonpower-limited circuit wiring must remain separated in the cabinet. All power-limited circuit wiring must remain at least 0.25" (6.35 mm) away from any nonpower-limited circuit wiring. Furthermore, all power-limited and nonpower-limited circuit wiring must enter and exit the cabinet through different knockouts and/or conduits. A typical wiring diagram for the MS-4 is illustrated below.

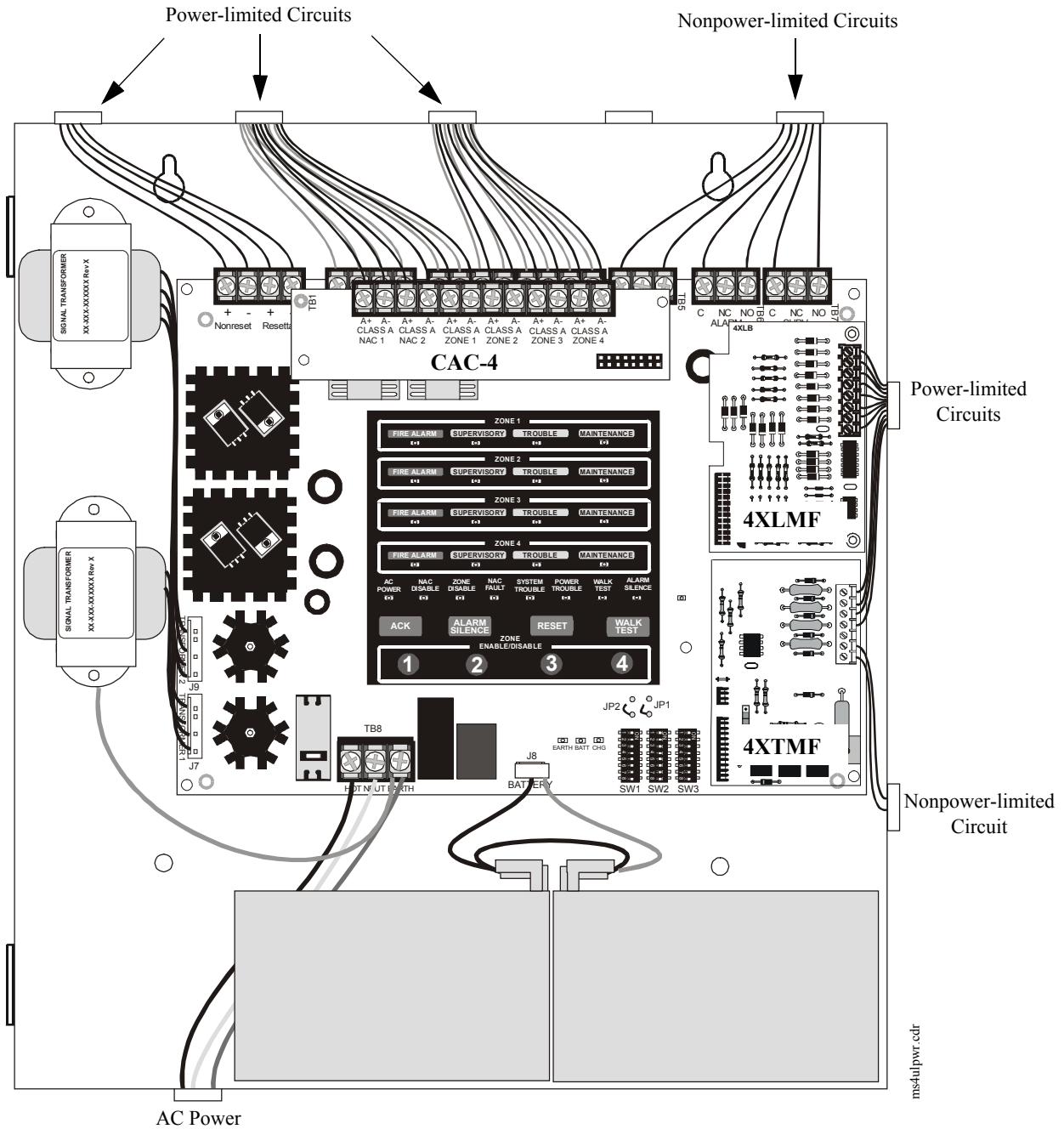

Figure 2.9 Typical UL Power-limited Wiring Requirements

2.6 Installation of Optional Modules



CAUTION: Remove all power (AC and DC) before installing or removing modules or wiring.

2.6.1 CAC-4 Class A Converter Module (MS-4 only)

2.6.1.1 Installation

The CAC-4 Module can be used to convert the four Style B (Class B) Initiating Device Circuits to Style D (Class A) and the two Style Y (Class B) Notification Appliance Circuits to Style Z (Class A). The module plugs into connector J1 which is located at the top right of the MS-4 main circuit board.

Install the three supplied standoffs in the holes on the main circuit board as indicated in the following figure. Carefully align the connector on the CAC-4 with J1 on the FACP main circuit board and press the module securely into place. Make certain the pins are properly aligned to prevent bending or breaking of any connector pins.

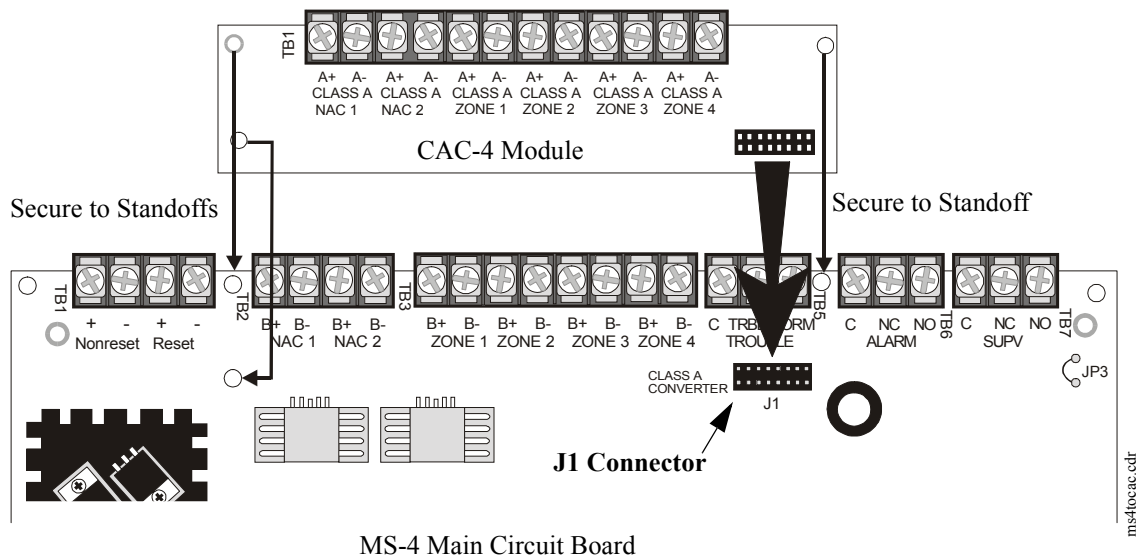

Figure 2.10 CAC-4 Module Installation

2.6.1.2 Wiring NACs and IDCs for Class A

Wire the Style Z (Class A) Notification Appliance Circuits using TB2 of the MS-4 and TB1 of the CAC-4 module. Wire the Style D (Class A) Initiating Device Circuits using TB3 of the MS-4 and TB1 of the CAC-4. Make certain to observe polarity when connecting the devices to the circuits. The B+ and A+ terminals must comprise the feed and return for the positive side of a device and the B- and A- terminals must comprise the feed and return for the negative side of a device. To configure any of the zones for Class B when the CAC-4 is installed, simply wire to the B+ and B- input on the FACP terminal(s) and install the End-of-Line Resistor after the last device on the circuit. Do not wire to the corresponding A+ and A- terminals on the CAC-4 module. Note that Zone 1 IDC on the MS-2 and Zone 2 IDC on the MS-4 can be configured as a combination waterflow/supervisory circuit as illustrated in the following figure.

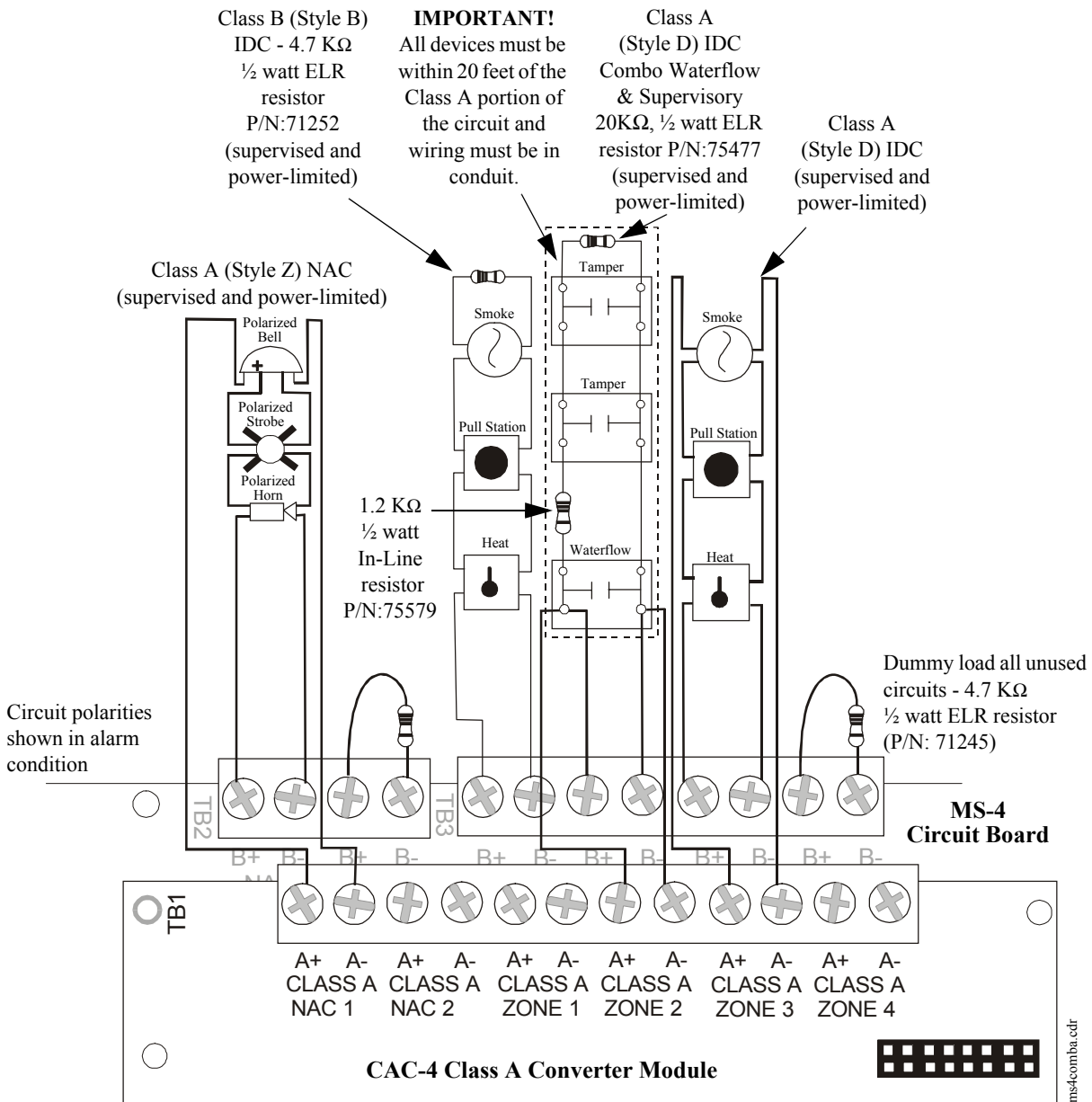

Figure 2.11 Wiring NACs and IDCs for Class A Operation

2.6.2 4XTMF, 4XLMF and 4XZMF Option Modules (MS-4 only)

The 4XLMF LED Interface Module can only be plugged into connectors J3 and J5 on the MS-4 main circuit board. The 4XTMF and 4XZMF modules can be plugged into connectors J3 and J5 or J4 and J6 on the MS-4 main circuit board. A combination of any two of the three modules can be installed. The following steps must be followed when installing each of these modules:

1. Remove all power (AC and DC) from the FACP before installing the modules
2. Cut jumper JP1 (for connectors J3 and J5) and/or JP2 (for connectors J4 and J6) on the main circuit board to allow the control panel to supervise the placement of any installed option module
3. Install the two supplied metal standoffs in the locations indicated. These standoffs provide the required earth ground protection
4. Carefully plug the connectors on the option module into connectors J3 and J5 or J4 and J6 on the FACP main circuit board, being careful not to bend any pins
5. Secure the option module to the standoff on the main circuit board with the supplied screws
6. When the installation has been completed, connect the wiring to the modules as indicated in the following sections
7. Test system for proper operation

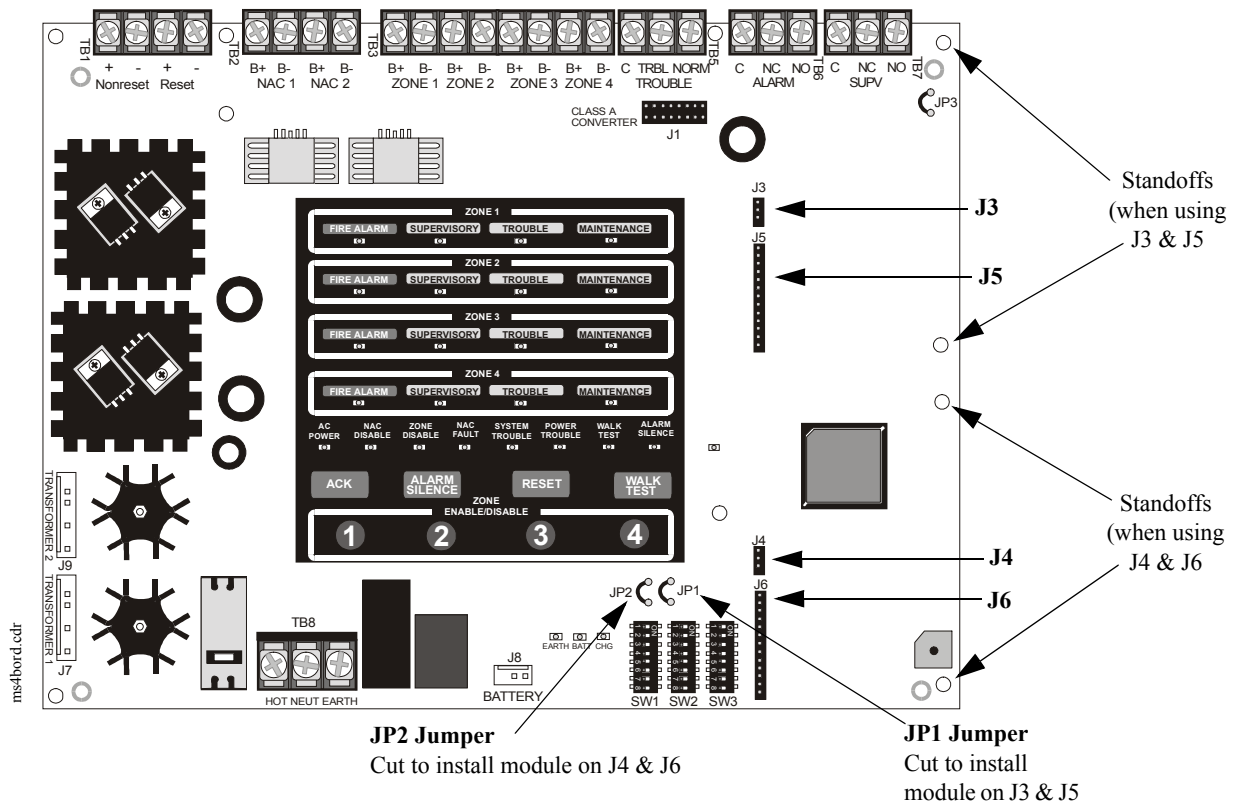

Figure 2.12 4X Option Module Connection to MS-4

2.6.2.1 4XTMF Transmitter Module Installation (MS-4 only)

The 4XTMF provides a supervised output for a local energy municipal box transmitter in addition to alarm and trouble reverse polarity. A jumper option allows the reverse polarity circuit to open with a system trouble condition if no alarm condition exists. A disable switch allows disabling of the transmitter output during testing to prevent accidental calling of the monitoring service.

Local Energy Municipal Box Service (NFPA 72 Auxiliary Fire Alarm Systems):

- Supervisory Current: 5.0 mA
- Trip Current: 350 mA (subtracted from notification appliance power)
- Coil Voltage: 3.65 VDC
- Maximum Coil Resistance: 14.6 ohms
- Maximum allowable wire resistance between panel and trip coil: 3 ohms
- Municipal Box wiring can leave the building

Remote Station Service (NFPA 72 Remote Station Fire Alarm Systems) - Intended for connection to a polarity reversal circuit or a Remote Station receiving unit having compatible ratings:

- Maximum load for each circuit: 10 mA
- Reverse polarity output voltage: 24 VDC
- Remote Alarm and Remote Trouble wiring can leave the building

Before installing the module, place the disconnect switch to the down (disconnect) position to prevent accidental activation of the municipal box. Note that a Disconnect LED will illuminate after the module is installed in the FACP. In addition, the System Trouble LED will turn on to indicate the Disconnect condition.

Note: 4XTMF Module is not suitable for transmitting reverse polarity supervisory signal.

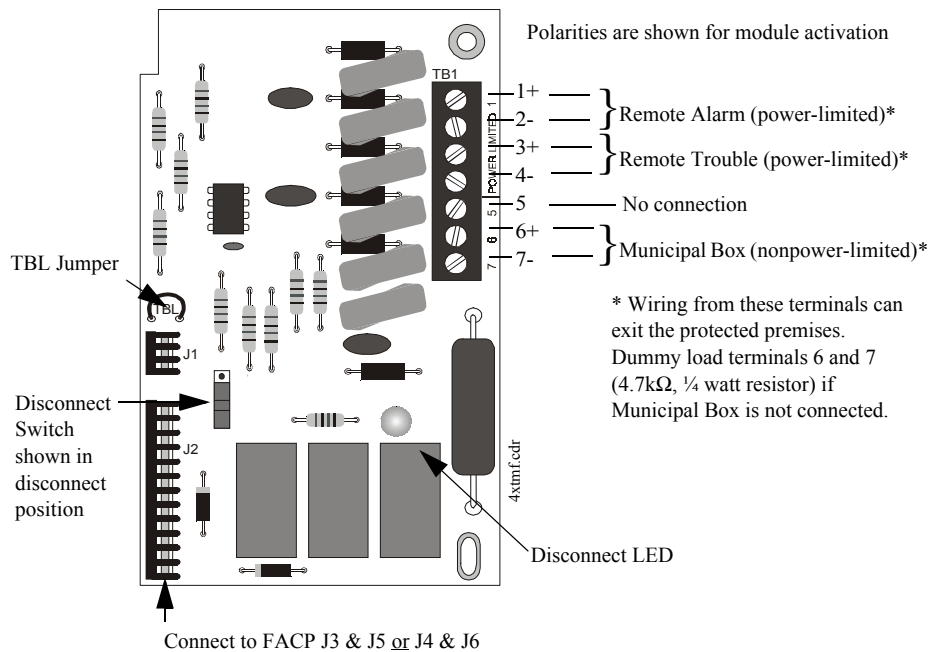
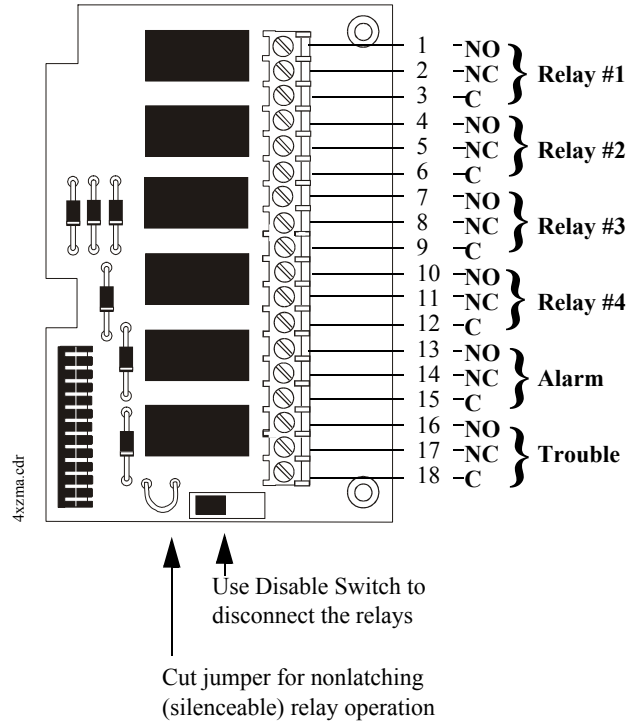

Figure 2.13 4XTMF Transmitter Module

2.6.2.2 4XZMF Zone Relay Module (MS-4 only)

The 4XZMF provides four zone alarm, one system alarm and one system trouble Form-C relays. Nonpower-limited and power-limited wiring must have a minimum distance of 0.25", wire to wire. If this module is used to drive nonpower-limited and power-limited circuits, follow the instructions below:

Relay #1 through #4 will activate with Output #1 through #4 and remain latched unless 'LATCH' jumper is cut.



1) Skip a set of dry contacts to maintain the 0.25" required space between power-limited and nonpower-limited circuits. The wiring of this module must follow the requirements as specified in "Power-limited Wiring Requirements" on page 24.

OR

2) If this module is needed to drive power-limited and nonpower-limited relays that are next to each other, refer to the following illustration which shows a typical connection:

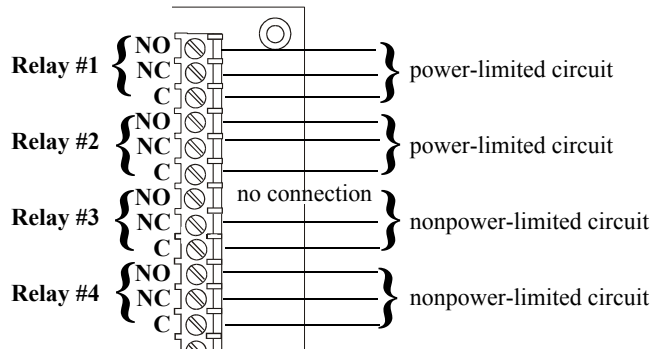

Figure 2.14 4XZMF Zone Relay Module

2.6.2.3 4XLMF LED Interface Module (MS-4 only)

The 4XLMF supports the RZA-4XF Remote Annunciator module. The wiring of this module must follow the requirements as specified in "Power-limited Wiring Requirements" on page 24.

Important: The 4XLMF module can only be installed on connectors J3 and J5 of the MS-4 main circuit board.

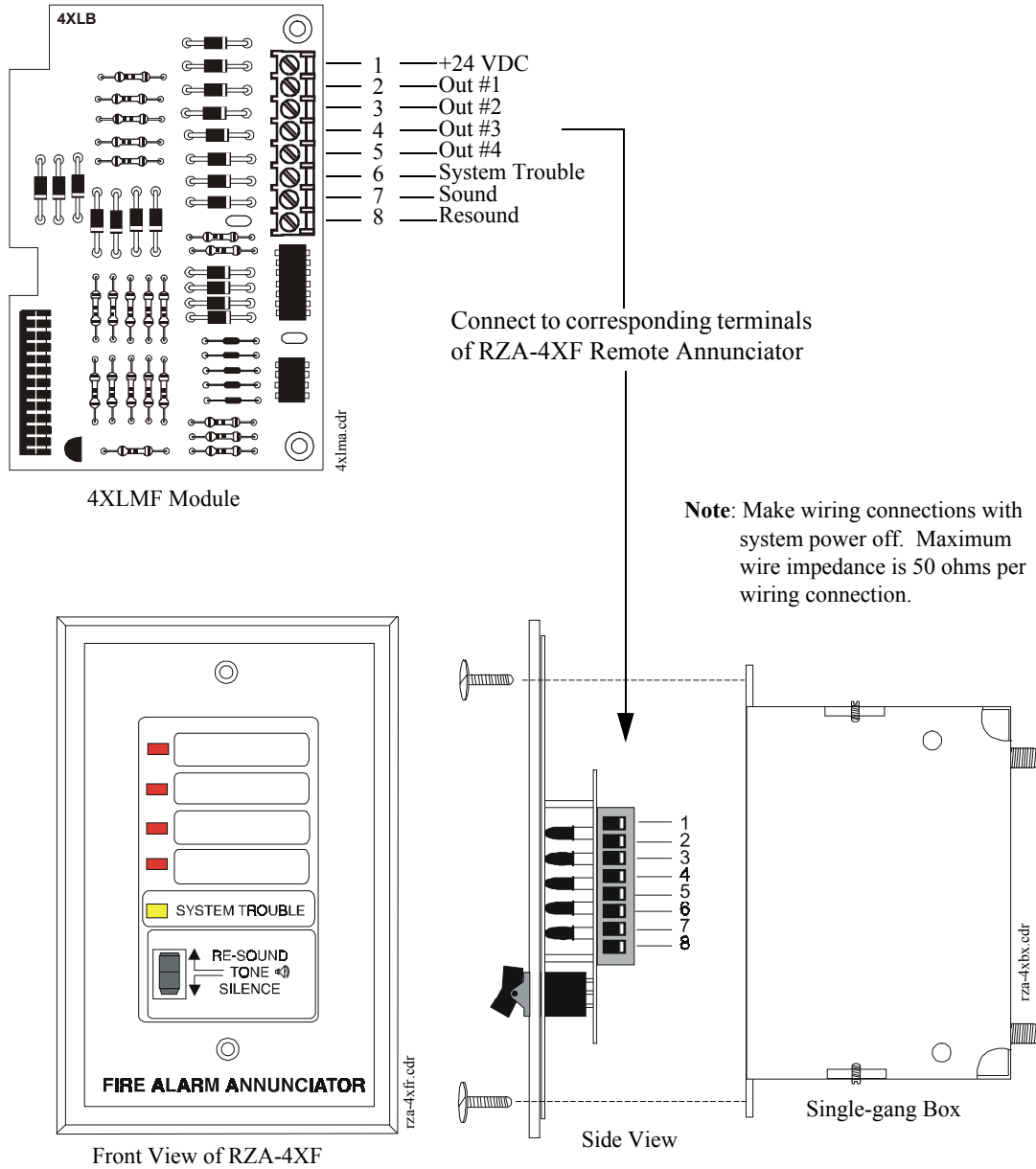

Figure 2.15 4XLMF LED Interface Module

SECTION 3 Program Options via DIP Switch

This section describes the programming options available via DIP switch settings. The FACP can be field programmed using option DIP switches SW1, SW2 and SW3 which are located in the bottom right side of the main circuit board. Refer to the following illustration for switch locations and DIP switch placement in the ON and OFF positions.

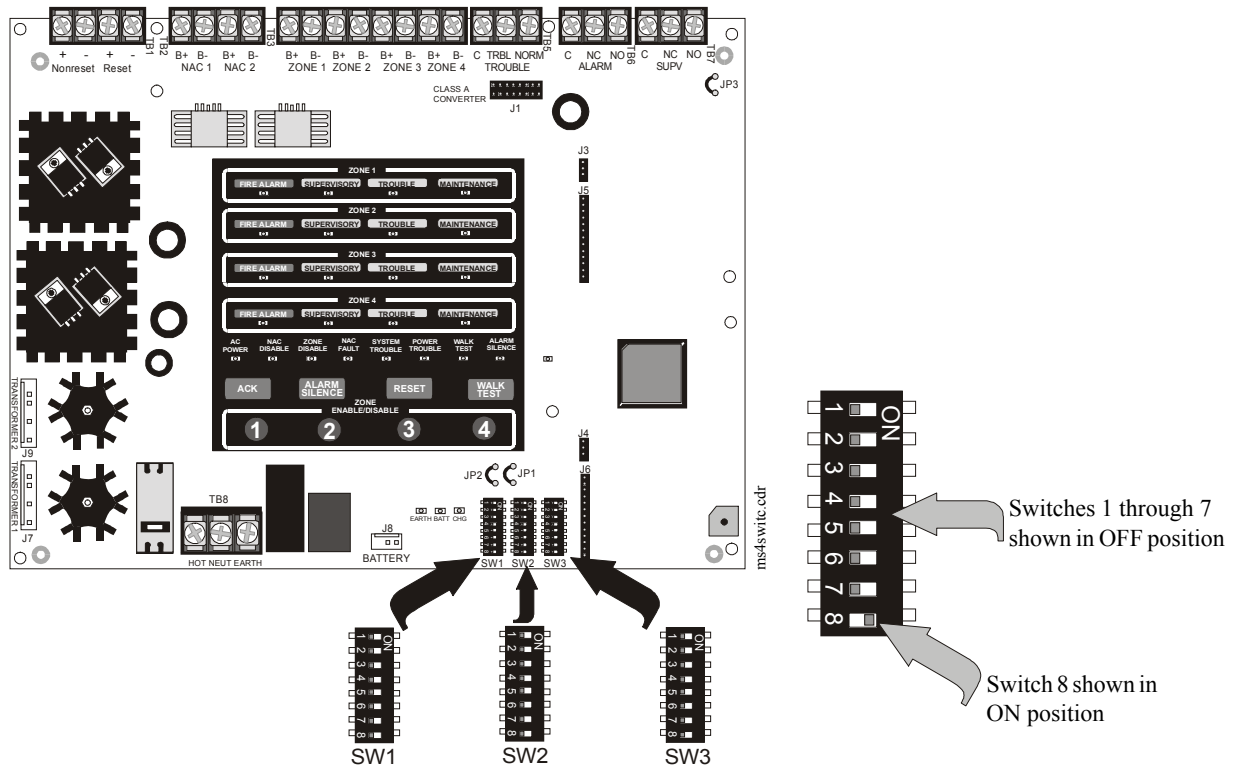

Figure 3.1 Field Programming DIP Switches

3.1 DIP Switch Settings

The following tables list the programmable features for the MS-2 and MS-4. Placing a DIP switch in the ON position will select the feature while placing the DIP switch in the OFF position will deselect the feature. The exceptions to this rule are SW3 DIP switches 5 & 6. These two switches are used to select the Notification Appliance Circuit synchronization feature. A detailed description of each feature is presented in the following pages.

Important: When any programmable feature is changed by repositioning a DIP switch, the FACP Reset button must be pressed to ensure that the control panel can read the new switch position.

Table 3.1 MS-2 DIP Switch Settings

Switch Number	DIP Switch Number	DIP Switch ON	
SW1	1	Silence Inhibit	
	2	Auto-silence	
	3	Temporal Coding	
	4	Selective Silence (if sync. enabled)	
	5	Trouble Reminder	
	6	AC Trouble Delay	
	7	Autoresettable Supervisory	
	8	IDC Combination Waterflow/ Supervisory Circuit	
SW2	1	<i>not used</i>	
	2	<i>not used</i>	
	3	IDC1 Verification	
	4	IDC1 Supervisory	
	5	IDC2 Verification	
	6	IDC2 Supervisory	
	7	<i>not used</i>	
	8	<i>not used</i>	
SW3	1	NAC1 Nonsilenceable	
	2	NAC1 Disable	
	3	<i>not used</i>	
	4	<i>not used</i>	
	5 & 6 used to select strobe synchronization feature as shown to the right	Switch 5 Switch 6	
		No Synchronization	OFF OFF
		System Sensor Synchronization	ON OFF
		Gentex Synchronization	OFF ON
		Wheelock Synchronization	ON ON
	7	Nonsilenceable Waterflow for Combination Circuit (only if SW1 switch 8 is ON)	
8	spare		

Table 3.2 MS-4 DIP Switch Settings

Switch Number	DIP Switch Number	DIP Switch ON			
SW1	1	Silence Inhibit			
	2	Auto-silence			
	3	Temporal Coding			
	4	Selective Silence (if sync. enabled)			
	5	Trouble Reminder			
	6	AC Trouble Delay			
	7	Autoresettable Supervisory			
	8	IDC Combination Waterflow/ Supervisory Circuit			
SW2	1	IDC1 Verification			
	2	IDC1 Supervisory			
	3	IDC2 Verification			
	4	IDC2 Supervisory			
	5	IDC3 Verification			
	6	IDC3 Supervisory			
	7	IDC4 Verification			
	8	IDC4 Supervisory			
SW3	1	NAC1 Nonsilenceable			
	2	NAC1 Disable			
	3	NAC2 Nonsilenceable			
	4	NAC2 Disable			
	5 & 6 used to select strobe synchronization feature as shown to the right	No Synchronization		Switch 5	Switch 6
		System Sensor Synchronization		OFF	OFF
		Gentex Synchronization		ON	OFF
		Wheelock Synchronization		OFF	ON
			ON	ON	
	7	Nonsilenceable Waterflow for Combination Circuit (only if SW1 switch 8 is ON)			
8	spare				

3.1.1 SW1 DIP Switch Settings

3.1.1.1 Silence Inhibit

Switch 1, placed in the ON position, selects the Silence Inhibit feature. This feature prevents the silencing or resetting of the NACs (Notification Appliance Circuits) for a period of one minute after initiation of an alarm. Placing switch 1 to the OFF position deselects the Silence Inhibit feature. The factory default setting is switch 1 OFF for no Silence Inhibit.

3.1.1.2 Auto-silence

Switch 2, placed in the ON position, selects the Auto-silence feature. This feature automatically silences all NACs, programmed for silenceable operation, ten minutes after alarm activation. A new activation on another zone will resound the NACs. The factory default setting is switch 2 OFF for no Auto-silence.

3.1.1.3 Temporal Coding

Switch 3, placed in the ON position, selects the Temporal Coding feature. This feature causes the NACs to pulse, ½ second on, ½ second off, ½ second on, ½ second off, ½ second on, 1½ seconds off, continually repeating this pattern while activated. The factory default setting is switch 3 OFF for no Temporal Coding, which will cause the NACs to sound a steady signal when activated.

Note that Temporal Coding is disabled if Strobe Synchronization is enabled.

3.1.1.4 Selective Silence

Switch 4, placed in the ON position, selects the Selective Silence feature. This feature allows the use of various manufacturer's horn strobe mute protocols. When Selective Silence is enabled and the Synchronization feature is selected (refer to "Strobe Synchronization" on page 37), pressing the Acknowledge or the Silence button will turn off all silenceable audible devices while leaving on the visual devices, such as strobes. The factory default setting is switch 4 OFF for no Selective Silence.

Note: Enabling Selective Silence but not Synchronization will cause audible and visual devices to be turned off when the Silence button is pressed.

3.1.1.5 Trouble Reminder

Switch 5, placed in the ON position, selects the Trouble Reminder feature. This feature causes the FACP piezo to sound every 15 seconds for alarms and every two minutes for troubles after the alarms or troubles have been silenced. In addition, the piezo will resound 24 hours after a trouble has been silenced but not cleared. The factory default setting is switch 5 OFF for Trouble Reminder disabled.

3.1.1.6 AC Trouble Delay

Switch 6, placed in the ON position, selects the AC Trouble Delay feature. This feature allows the FACP to delay trouble activation for six hours following an AC loss or brownout condition. The factory default setting is switch 6 OFF for no AC Trouble Delay.

3.1.1.7 Autoresettable Supervisory

Switch 7, placed in the ON position, selects the Autoresettable Supervisory feature. This feature causes the IDCs (Initiating Device Circuits), programmed as supervisory circuits, to automatically reset (nonlatching) after the alarm condition has been cleared. The factory default setting is switch 7 OFF for no Autoresettable Supervisory.

3.1.1.8 IDC Combination Circuit

Switch 8, placed in the ON position, sets IDC #1 on the MS-2 or IDC #2 on the MS-4 as a combination circuit. A combination zone can be used for monitoring supervisory devices such as valve tamper switches and alarm devices such as waterflow switches. Supervisory conditions, which latch via software, can be silenced by pressing the Acknowledge and then Silence buttons. The factory default setting is switch 8 OFF for no Combination circuit.

3.1.2 SW2 DIP Switch Settings

3.1.2.1 IDC1 Verification (MS-4 only)

Switch 1 only on the MS-4, placed in the ON position, selects the Verification feature for IDC (Initiating Device Circuit) #1. When Verification is selected the following events will occur when a smoke detector activates:

1. FACP removes power from all zones for 6 seconds, resetting all smoke detectors
2. Power is reapplied and a 12 second retard period begins, allowing detectors to stabilize
3. During the 18 second reset/retard periods of steps 1 & 2, subsequent alarms by the same zone are ignored
4. Alarms detected on any other zone during the retard period will cause the FACP to immediately process the alarm
5. A confirmation period follows the reset/retard period. If an alarm occurs during the confirmation period, on the zone which initiated verification, the FACP will immediately process the alarm. If no alarm is detected during this confirmation period, the FACP returns to normal condition

Important! *Circuits selected for verification must have only smoke detectors installed*

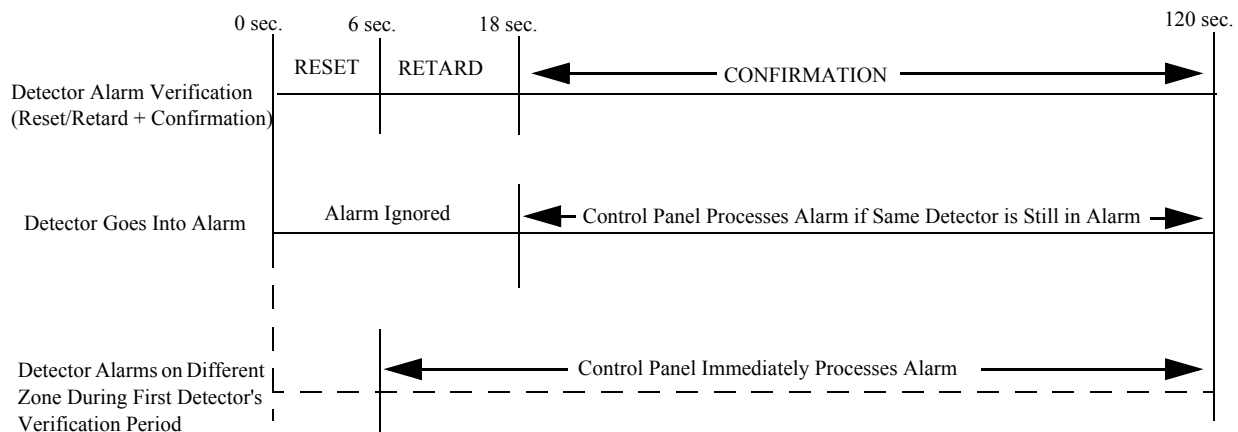

The factory default setting is switch 1 OFF for no IDC1 Verification.

3.1.2.2 IDC1 Supervisory (MS-4 only)

Switch 2 only on the MS-4, placed in the ON position, programs IDC #1 as a Supervisory circuit. A supervisory zone can be used for monitoring supervisory devices such as sprinkler tamper switches. A supervisory activation will pulse the piezo sounder at a 1/2 second rate and flash the zone supervisory LED at the same rate. The factory default setting is switch 2 OFF for no IDC1 Supervisory.

3.1.2.3 IDC1 Verification for MS-2 or IDC2 Verification for MS-4

Switch 3, placed in the ON position, selects the Verification feature for IDC #1 on the MS-2 or IDC #2 on the MS-4. The factory default setting is switch 3 OFF for no Verification. Refer to IDC1 Verification (MS-4 only) for a description of this feature.

3.1.2.4 IDC1 Supervisory for MS-2 or IDC2 Supervisory for MS-4

Switch 4, placed in the ON position, programs IDC #1 on the MS-2 or IDC #2 on the MS-4 as a Supervisory circuit. A supervisory zone can be used for monitoring supervisory devices such as sprinkler tamper switches. A supervisory activation will pulse the piezo sounder at a 1/2 second rate and flash the zone supervisory LED at the same rate. The factory default setting is switch 2 OFF for no Supervisory.

3.1.2.5 IDC2 Verification for MS-2 or IDC3 Verification for MS-4

Switch 5, placed in the ON position, selects the Verification feature for IDC #2 on the MS-2 or IDC #3 on the MS-4. The factory default setting is switch 5 OFF for no Verification. Refer to "IDC1 Verification (MS-4 only)" on page 35 for a description of this feature.

3.1.2.6 IDC2 Supervisory for MS-2 or IDC3 Supervisory for MS-4

Switch 6, placed in the ON position, programs IDC #2 on the MS-2 or IDC #3 on the MS-4 as a Supervisory circuit. A supervisory zone can be used for monitoring supervisory devices such as sprinkler tamper switches. A supervisory activation will pulse the piezo sounder at a ½ second rate and flash the zone supervisory LED at the same rate. The factory default setting is switch 6 OFF for no Supervisory.

3.1.2.7 IDC4 Verification (MS-4 only)

Switch 7 only on the MS-4, placed in the ON position, selects the Verification feature for IDC #4. The factory default setting is switch 7 OFF for no IDC4 Verification. Refer to "IDC1 Verification (MS-4 only)" on page 35 for a description of this feature.

3.1.2.8 IDC4 Supervisory (MS-4 only)

Switch 8 only on the MS-4, placed in the ON position, programs IDC #4 as a Supervisory circuit. A supervisory zone can be used for monitoring supervisory devices such as sprinkler tamper switches. A supervisory activation will pulse the piezo sounder at a ½ second rate and flash the zone supervisory LED at the same rate. The factory default setting is switch 8 OFF for no IDC4 Supervisory.

3.1.3 SW3 DIP Switch Settings**3.1.3.1 NAC1 Nonsilenceable**

Switch 1, placed in the ON position, programs NAC #1 as a nonsilenceable circuit. Selecting this feature will prevent the notification appliances on NAC #1 from being silenced by the Autosilence feature or by pressing the Alarm Silence button. The factory default setting is switch 1 OFF for silenceable circuit.

3.1.3.2 NAC1 Disable

Switch 2, placed in the ON position, will disable NAC #1, preventing the notification appliances from activating. This feature may be used during maintenance or while testing the system to prevent building evacuation. The FACP will indicate an NAC disabled fault and system trouble while this feature is selected. The factory default setting is switch 2 OFF for NAC1 enabled.

3.1.3.3 NAC2 Nonsilenceable (MS-4 only)

Switch 3 only on the MS-4, placed in the ON position, programs NAC #2 as a nonsilenceable circuit. Selecting this feature will prevent the notification appliances on NAC #2 from being silenced by the Autosilence feature or by pressing the Alarm Silence button. The factory default setting is switch 3 OFF for silenceable circuit.

3.1.3.4 NAC2 Disable (MS-4 only)

Switch 4 only on the MS-4, placed in the ON position, will disable NAC #2, preventing the notification appliances from activating. This feature may be used during maintenance or while testing the system to prevent building evacuation. The FACP will indicate an NAC disabled fault and system trouble while this feature is selected. The factory default setting is switch 4 OFF for NAC2 enabled.

3.1.3.5 Strobe Synchronization

Switches 5 and 6 are used to program the Synchronization feature. This feature controls the activation of notification appliances in such a way that all devices will turn on and off at exactly the same time. This is particularly critical when activating strobes which must be synchronized to avoid random activation and a potential hazard or confusion. The FACP can be programmed to operate with a variety of manufacturer's devices. The following table lists the required switch settings to accomplish synchronization:

Synchronization Feature	Switch 5	Switch 6
No Synchronization	OFF	OFF
System Sensor Synchronization	ON	OFF
Gentex Synchronization	OFF	ON
Wheelock Synchronization	ON	ON

The factory default setting is switches 5 and 6 OFF for No Synchronization.

3.1.3.6 Nonsilenceable Waterflow for Combination Circuit

If SW1 switch 8 is set to the ON position to select a Combination Waterflow/Supervisory Circuit (refer to "IDC Combination Circuit" on page 34) and SW3 switch 7 is set to the ON position to select the Nonsilenceable Waterflow for the Combination Circuit option, the following conditions will occur:

- MS2 - NACs become nonsilenceable upon activation of IDC #1 (Combination Circuit)
- MS4 - NACs become nonsilenceable upon activation of IDC #2 (Combination Circuit)

Notes:

- 1.If initial alarm activations are from IDCs other than the Combination Circuit, the NACs will be either silenceable or nonsilenceable, depending on the setting of SW3 switches 1 and 3 (refer to "NAC1 Nonsilenceable" on page 36 and "NAC2 Nonsilenceable (MS-4 only)" on page 36).
- 2.If alarm activation is from the Combination Circuit programmed for nonsilenceable, all NACs will be nonsilenceable regardless of subsequent IDC activations.

3.1.3.7 Spares

Switch 8 is a spare switch and has no function at this time. The switch should therefore be left in the factory default setting of OFF.

SECTION 4 Operating Instructions

The MS-2 and MS-4 have two modes of operation which are Normal and Walktest modes. Upon initial power-up, the system will be in Normal Mode. This section discusses operation of the control panel in the Normal Mode.

4.1 Switch Functions in Normal Mode

4.1.1 ACK - Acknowledge

The Acknowledge button, which is located on the FACP membrane switch panel, silences the system piezo sounder and changes all flashing system LEDs to on steady. Pressing the Acknowledge button will have no effect on the Notification Appliance Circuits. To activate, press and hold the Acknowledge button for a minimum of one second.

4.1.2 Silence

Pressing the Silence button, which is located on the FACP membrane switch panel, silences the system piezo sounder, turns off the silenceable Notification Appliance Circuits and turns on the Alarm Silence LED. *The Silence button will be ignored for nonsilenceable waterflows and NACs.* Upon the occurrence of a subsequent event (alarm or trouble), Silence is overridden and the control panel will respond to the new event. To activate, press the Silence button for a minimum of one second.

Note: If Silence Inhibit has been enabled, NACs cannot be silenced for one minute following initiation of an alarm.

4.1.3 Zone Enable/Disable

To disable a zone, press the corresponding Zone Enable/Disable button. The Zone Disable and system Trouble LEDs will blink, as well as the Trouble LED for the disabled zone. To enable the zone, press the Zone Enable/Disable button a second time.

4.1.4 Reset/(Lamp Test)

The system Reset button, which is located on the FACP membrane switch panel, resets the system and any smoke detectors. Each press of the Reset button will cause the following:

- ✓ Clear all status LEDs
- ✓ Turn off the Notification Appliance Circuits
- ✓ Reset all zones by temporarily removing power
- ✓ Silence the onboard piezo sounder
- ✓ Restore all system relays to normal
- ✓ Temporarily remove power from the resettable power output

Note: if Silence Inhibit is active, a panel reset cannot occur for one minute.

Any alarm, supervisory or trouble condition that exists after a system reset will resound the system, reactivating appropriate system activity. Any zones that were disabled before the reset will be disabled after the reset.

Lamp Test - When the Reset button is pressed and then released, the FACP will perform a Lamp Test. All panel LEDs will be turned on and the piezo will sound for approximately two seconds.

4.1.5 Walktest

The Walktest button, which is located on the FACP membrane switch panel, allows a panel walktest to be performed. Pressing and holding the Walktest button for a minimum of two seconds causes the FACP to enter audible walktest. Pressing the Walktest button and then the Silence button and holding both for a minimum of two seconds will cause the panel to enter silent walktest. Walktest can be exited by pressing and holding the Walktest button for a minimum of three seconds or by pressing the Reset button. Refer to “Walktest” for a complete description of this feature.

4.2 Walktest

Walktest allows the testing of all control panel IDCs (input zones). An audible or silent walktest may be performed.



It is important to note that while the FACP is in Walktest mode, the control panel is in an off-normal condition and does not provide fire protection.

It should also be noted that the trouble relay will be activated while the control panel is in Walktest mode. Placing the control panel into Walktest mode will only be possible if the system has no active alarms.

Prior to initiating a walktest, check to make certain that **all system faults have been cleared**. Upon entering Walktest mode, the following conditions should occur:

- Trouble relay will activate
- Alarm relay will be disabled
- Supervision relay will be disabled (MS-4 only)
- Piezo sounder will be disabled
- F³ smoke detectors will enter their own test mode causing their LEDs to flash twice every five seconds (refer to the F³ specification document)
- All alarm conditions will be displayed as they occur by blinking zone alarm LED
- All zone troubles will be displayed as they occur by blinking zone trouble LED

During walktest, the FACP zone LEDs will blink for the first activation on a zone. Subsequent activations on the same zone will cause the corresponding zone LED to blink the number of alarms on the zone since the start of the test, followed by a two second pause and then a repeat of the sequence.

Note that following a zone activation, a 6 second reset for conventional and 60 second reset for F³ detectors is initiated. No new alarms or troubles will be detected during this reset period.

Disabled zones will not respond during Walktest. A zone may be disabled while in Walktest mode, should a faulty device be detected. This allows the user to return the system to Normal mode, enabling all other zones while preventing the faulty zone from triggering a false alarm.

Audible Walktest

To perform an audible Walktest, press and hold the Walktest button for a minimum of two seconds. The Trouble and Walktest LEDs will blink at a ¼ second rate.

While testing input devices, the first initiating device activated on a zone will cause the NACs to sound for four seconds. Subsequent device activations on the same zone will cause the NACs to turn on for one second. Any smoke detectors that are activated will automatically be reset by the panel. Zone faults (open circuits) will cause the NACs to remain on steadily until the fault is cleared.

During an audible walktest, if a device remains latched in alarm (such as a Pull Station that is not reset after activation), subsequent testing of devices on the same zone will not trigger the NACs. Be certain to reset or clear each device after testing.

Silent Walktest

To perform a silent Walktest, press the Walktest button, then press the Alarm Silence button and hold both for a minimum of two seconds. The Trouble, Walktest and Alarm Silence LEDs will blink at a ¼ second rate.

A silent walktest will not activate the control panel Notification Appliance Circuits. All alarm and trouble conditions must be observed using the LEDs at the control panel as described in the previous sections.

Exiting Walktest Mode

Walktest mode can be exited by pressing and holding the Walktest button for a minimum of three seconds or by pressing the Reset button. *The time-out feature will cause the control panel to automatically exit Walktest mode if no button presses have occurred for one hour.*

4.3 Status LEDs

AC Power LED

A green LED that remains on while the AC power supply is within correct limits. *If this indicator fails to light under normal conditions, service the system immediately.*

NAC Disable LED

A yellow LED that blinks to indicate that a Notification Appliance Circuit has been disabled using the main circuit board DIP switches. The LED will turn on steady when the Acknowledge or Alarm Silence button is pressed.

Zone Disable LED

A yellow LED that blinks to indicate that one or more alarm zones have been disabled using the Zone Enable/Disable buttons. The disabled zone's trouble LED will also be on. The Acknowledge or Alarm Silence button does not affect the Zone Disable LED.

NAC Fault LED

A yellow LED that blinks to indicate that an NAC trouble condition exists in the system. The LED turns on steady when the Acknowledge or Alarm Silence button is pressed.

System Trouble LED

A yellow LED that blinks to indicate that a system fault or abnormal condition exists and that the fire alarm system may be inoperative. It turns on steady when the Acknowledge or Alarm Silence button is pressed.

Power Trouble LED

A yellow LED that blinks to indicate an AC power, battery or charger trouble condition. It turns on steady when the Acknowledge or Alarm Silence button is pressed.

Walktest LED

A yellow LED that blinks to indicate that the control panel is in Walktest mode. The Acknowledge and Alarm Silence buttons do not affect the Walktest LED.

Alarm Silence LED

A yellow LED that turns on to indicate that an Alarm condition exists in the system but the Notification Appliance Circuits and the local piezo sounder have been silenced.

Zone Fire Alarm LED

A red LED for each zone that blinks to indicate that an alarm exists on the corresponding zone. It turns on steady when the Acknowledge or Alarm Silence button is pressed.

Zone Supervisory LED

A yellow LED for each zone that blinks if the zone has been programmed for supervisory and a supervisory condition exists on the corresponding zone. It turns on steady when the Acknowledge or Alarm Silence button is pressed.

Note that an I³ smoke detector freeze condition is displayed as a supervisory condition. The zone does not have to be programmed as a supervisory for this to occur.

Zone Trouble LED

A yellow LED for each zone that blinks to indicate that a trouble exists on the corresponding zone. It turns on steady when the Acknowledge or Alarm Silence button is pressed.

Zone Maintenance LED

A yellow LED for each zone that blinks to indicate that a I³ smoke detector on the corresponding zone is dirty or in need of maintenance. It turns on steady when the Acknowledge or Alarm Silence button is pressed.

Earth Fault LED (on main circuit board)

A yellow LED that blinks to indicate a ground fault condition on the system. A ground fault occurs when a low resistance between the FACP and earth ground exists. The LED turns on steady when the Acknowledge or Alarm Silence button is pressed.

Battery Fault LED (on main circuit board)

A yellow LED that blinks to indicate a low battery or no battery condition on the FACP. It turns on steady when the Acknowledge or Alarm Silence button is pressed.

Charger Fault LED (on main circuit board)

A yellow LED that blinks to indicate a battery charger fault. It turns on steady when the Acknowledge or Alarm Silence button is pressed.

4.4 Operation

Normal mode is the standard mode of operation. In this mode, the panel continuously monitors system status. When no alarm or trouble conditions exist, the control panel will be in the following state:

- all LEDs will be off (except the AC Power LED)
- the Notification Appliance Circuits will be off
- all relays are in their normal state
- the onboard piezo sounder will be off
- I3 smoke detectors will be polled for maintenance and freeze conditions on initial entry into Normal mode. Thereafter, each device will be polled every hour for freeze and every four hours for maintenance conditions

All alarm and system trouble conditions are annunciated on the control panel's LEDs.

Note: To ensure that the system is functioning properly, the FACP will perform a freeze check five minutes after the panel is reset, followed by a maintenance check. If there is no freeze or maintenance condition, the panel will continue to monitor for freeze conditions every hour and maintenance conditions every four hours.

4.4.1 Fire Alarm Response

The control panel will, upon detection of an alarm condition, cause the following:

- Latch the alarm condition - requires panel reset to clear alarm condition
- Blink the Zone Alarm LED one second On and one second Off
- Turn on remote annunciator alarm LED and piezo sounder
- Turn the Notification Appliance Circuit(s) on
- Turn the FACP piezo sounder on steady
- Turn on the alarm relay
- Start the Silence Inhibit, Auto-silence and Trouble Reminder functions if enabled

4.4.2 Fire Alarm Restoral

The control panel returns to normal after all alarms have been cleared and a system reset button has been pressed (pull stations have been reset, smoke detectors have reset and no smoke is present, waterflow has stopped). The control panel will perform the following upon restoral of all active alarms:

- Turn off the FACP Zone Alarm LED
- Turn off remote annunciator alarm LED and piezo sounder
- Turn off the Notification Appliance Circuit(s)
- Turn off the FACP piezo sounder
- Turn off the alarm relay
- I3 smoke detectors will be polled for maintenance and freeze conditions on initial entry into Normal mode. Thereafter, each device will be polled every hour for freeze and every four hours for maintenance conditions

4.4.3 System Supervisory Condition Response

Zones can be programmed for supervisory in applications where a waterflow sensing device has been employed and a sprinkler tamper switch is to be monitored. An I³ detector in a 'freeze' condition (detected abnormally low ambient temperature) will also generate a supervisory condition on its alarm zone (refer to the I³ specification sheet for temperature threshold). Any supervisory condition will cause the control panel to perform the following functions:

- Blink the FACP Zone Supervisory LED ½ second On and ½ second Off
- Pulse the piezo sounder ½ second On and ½ second Off
- Turn on the supervisory relay (MS-4 only)

4.4.4 System Supervisory Restoral Response

When the supervisory condition has been cleared, the control panel will perform the following:

- Turn off the FACP Zone Supervisory LED
- Turn off the piezo sounder
- Turn off the supervisory relay (MS-4 only)

4.4.5 Trouble Condition Response

The control panel, upon detection of one or more trouble conditions, will perform the following:

- Blink the FACP System Trouble LED one second On and one second Off
- Blink the FACP Zone Trouble LED one second On and one second Off
- Turn on remote annunciator Trouble LED and pulse the piezo sounder
- Pulse the FACP piezo sounder one second On and one second Off
- Transfer fail-safe Trouble relay
- Additional LEDs will turn on or blink according to the specific trouble
 - ✓ NAC Disable LED if NAC has been disabled
 - ✓ Zone Disable LED if a zone has been disabled
 - ✓ NAC Fault LED if a fault is detected on an NAC
 - ✓ Power Trouble LED if an AC, battery or charger fault is detected
 - ✓ AC Power LED will turn off if AC fail or brownout occurs
 - ✓ Alarm Silence LED if Silence button is pressed after an alarm or trouble
 - ✓ Walktest LED if Walktest mode is entered
 - ✓ Zone Maintenance LED if a I³ smoke detector needs servicing
 - ✓ Earth Fault LED if a ground fault occurs
 - ✓ Battery Fault LED if low or no battery condition occurs
 - ✓ Charger Fault LED if a charger trouble occurs

4.4.6 Trouble Condition Restoral

The control panel performs the following upon restoral of all trouble conditions:

- Turn off the FACP System Trouble LED
- Turn off the FACP Zone Trouble LED
- Turn off the remote annunciator Trouble LED and piezo sounder
- Turn off the piezo sounder
- Transfer the fail-safe Trouble relay
- Turn off additional LEDs corresponding to specific troubles

SECTION 5 Power Supply Calculations

5.1 Overview

This section contains instructions and tables for calculating power supply currents in alarm and standby conditions. This is a four-step process, consisting of the following:

1. Calculating the total amount of AC branch circuit current required to operate the system
2. Calculating the power supply load current for non-fire and fire alarm conditions and calculating the secondary (battery) load
3. Calculating the size of batteries required to support the system if an AC power loss occurs
4. Selecting the proper batteries for your system

5.2 Calculating the AC Branch Circuit

The control panel requires connection to a separate, dedicated AC branch circuit, which must be labeled **FIRE ALARM**. This branch circuit must connect to the line side of the main power feed of the protected premises. No other non-fire alarm equipment may be powered from the fire alarm branch circuit. The branch circuit wire must run continuously, without any disconnect devices, from the power source to the control panel. Overcurrent protection for this circuit must comply with Article 760 of the National Electrical Codes as well as local codes. Use 14 AWG (2.00 mm²) wire with 600 volt insulation for this branch circuit.

Use Table 5-1 , to determine the total amount of current, in AC amperes (A), that must be supplied to the system.

TABLE 5-1:120 VAC Branch Circuit Requirements

Device Type	Number of Devices		Current Draw (AC amps)		Total Current per Device
MS-2 or MS-4	1	X	2.3	=	2.3
	[]	X		=	
	[]	X	[]	=	
Sum Column for AC Branch Current Required				=	

5.3 Calculating the System Current Draw

5.3.1 Overview

The control panel must be able to power all internal and external devices continuously during the non-fire alarm condition. To calculate the non-fire alarm load on the system power supply when primary power is applied, use Calculation Column 1 in Table 5-3 on page 46. The control panel must support a larger load current during a fire alarm condition. To calculate the fire alarm load on the power supply, use Calculation Column 2 in Table 5-3 on page 46. The secondary power source (batteries) must be able to power the system during a primary power loss. To calculate the non-fire alarm load on the secondary power source, use Calculation Column 3 in Table 5-3 on page 46.

When calculating current draw and the battery size, note the following:

- ‘Primary’ refers to the main power source for the control panel
- ‘Secondary’ refers to the control panel’s backup batteries
- All currents are given in amperes (A). Table 5-2 shows how to convert milliamperes and microamperes to full amperes.

TABLE 5-2: Converting to Full Amperes

To convert...	Multiply	Example
Milliamperes (mA) to amperes (A)	mA x 0.001	3 mA x 0.001 = 0.003A
Microamperes (μ A) to amperes (A)	μ A x 0.000001	300 μ A x 0.000001 = 0.0003 A

5.3.2 How to Use Table 5-3 on page 46 to Calculate System Current Draw

Use Table 5-3 on page 46 to calculate current draws as follows:

1. Enter the quantity of devices in all three columns
2. Enter the current draw where required. Refer to the Fire-Lite Device Compatibility Document for compatible devices and their current draw
3. Calculate the current draws for each in all columns
4. Sum the total current for each column
5. Copy the totals from Column 2 and Column 3 to Table 5-4 on page 47

Following are the types of current that can be entered into Table 5-3 on page 46:

- ✓ **Calculation Column 1** - The primary supply current load that the control panel must support during a non-fire alarm condition, with AC power applied.
- ✓ **Calculation Column 2** - The primary supply current load that the control panel must support during a fire alarm condition, with AC power applied.
- ✓ **Calculation Column 3** - The standby current drawn from the batteries in a non-fire alarm condition during a loss of AC power.

Table 5-3 contains three columns for calculating current draws. For each column, calculate the current and enter the total (in amperes) in the bottom row. When finished, copy the totals from Calculation Column 2 and Calculation Column 3 to Table 5-4 on page 47.

TABLE 5-3: System Current Draw Calculations

Device Type	Calculation Column 1 Primary, Non-Fire Alarm Current (amps)			Calculation Column 2 Primary, Fire Alarm Current (amps)			Calculation Column 3 Secondary, Non-Fire Alarm Current (amps)		
	Qty	X[current draw]=	Total	Qty	X [current draw] =	Total	Qty	X[current draw]=	Total
Main Circuit Board MS-2 or MS-4	1	X[0.080]= X[0.085]=	0.	1	X[0.112] ¹ = X[0.175] ¹ =	0.	1	X[0.080]= X[0.085]=	0.
CAC-4	[]	X[0.001]=		[]	X[0.001]=		[]	X[0.001]=	
4XTMF	[]	X[0.005]=		[]	X[0.011] ¹ =		[]	X[0.005]=	
4XZMF	[]	X[0.004]=		[]	X[0.008]=		[]	X[0.004]=	
4XLMF/RZA-4XF pair	[] 1 pair max.	X[0.004]=		[]	X[0.019]=		[]	X[0.004]=	
2-wire Detector Heads	[]	X[] ² =		[]	X[]=		[]	X[]=	
4-wire Detector Heads	[]	X[] ³ =		[]	X[]=		[]	X[]=	
Power Supervision Relays ⁴	[]	X[0.025]=		[]	X[0.025]=		[]	X[0.025]=	
NAC #1 ⁵				[]	X[]=				
NAC #2				[]	X[]=				
Current Draw from TB1 (nonalarm ⁶)		[]=			[]=			[]=	
Sum each column⁷ for totals		Primary Non-Alarm =			Primary Alarm =			Secondary Alarm =	

Table Footnote

1. If using the Reverse Polarity Alarm output, add 0.005 amps; if using the Reverse Polarity Trouble output, add another 0.005 amps.
2. Refer to the Device Compatibility Document for standby current.
3. Refer to the Device Compatibility Document for standby current.
4. Must use compatible listed Power Supervision Relay.
5. Current limitation of Terminal TB2 circuits is 2.50 amps per NAC (MS-4 requires optional transformer for max. current)
6. The total standby current must include both the resettable (TB1 Terminals 3 & 4) and nonresettable for MS-4 only (TB1 Terminals 1 & 2) power. Caution must be taken to ensure that current drawn from these outputs during alarm does not exceed maximum ratings specified. Current limitations of TB1, Terminals 1 & 2 = 0.500 amps, filtered, 24 VDC +/-5%, 120 Hz ripple @ 10 mV_{RMS}, nonresettable power and TB1, Terminals 3 & 4 = 0.500 amps, filtered, 24 VDC +/-5%, 120 Hz ripple @ 10mV_{RMS}, resettable power.
7. Total current draw listed above cannot exceed 3.0 amps with only standard transformer installed or, for the MS-4, 6.0 amps with both the standard and optional transformers installed.

5.4 Calculating the Battery Size

Use Table 5-4 to calculate the total Standby and Alarm load in ampere hours (AH). This total load determines the battery size (in AH), required to support the control panel under the loss of AC power. Complete Table 5-4 as follows:

1. Enter the totals from Table 5-3 on page 46, Calculation Columns 2 and 3 where shown
2. Enter the NFPA Standby and Alarm times (refer to ‘NFPA Requirements’ below)
3. Calculate the ampere hours for Standby and Alarm, then sum the Standby and Alarm ampere hours
4. Multiply the sum by the derating factor of 1.2 to calculate the proper battery size (in AH)
5. Write the ampere hour requirements on the Protected Premises label located inside the cabinet door

TABLE 5-4: Total Secondary Power Requirements at 24 VDC

Secondary Standby Load (total from Table 5-3 Calculation Column 3) []	Required Standby Time (24 or 60 hours) X[]	= AH
Primary Alarm Load (total from Table 5-3 Calculation Column 2) []	Required Alarm Time (for 5 min., enter 0.084, for 10 min., enter 0.168) X[]	= AH
Sum of Standby and Alarm Ampere Hours		= AH
Multiply by the Derating Factor		X 1.2
Battery Size, Total Ampere Hours Required		= AH

5.4.1 NFPA Battery Requirements

- NFPA 72 Local, Central and Proprietary Fire Alarm Systems require 24 hours of standby power followed by 5 minutes in alarm
- NFPA 72 Auxiliary and Remote Station require 60 hours of standby followed by 5 minutes in alarm. Batteries installed in a system powered by a generator need to provide at least 4 hours of standby power

5.4.2 Selecting and Locating Batteries

Select batteries that meet or exceed the total ampere hours calculated in Table 5-4 . The control panel can charge batteries in the 7 AH to 18 AH range. The control panel cabinet is capable of housing batteries up to 7 AH. Batteries larger than 7 AH require the BB-17F or other UL listed external battery cabinet.

Notes

Index

Numerics

411 16

411UD 16

4XLMF

installation 27, 30

see also LED Interface Module 15

see also LED interface module 30

specifications 30

wiring to RZA-4XF 30

4XTMF

installation 27, 28

operation 28

see also Transmitter Module 15

see also transmitter module 28

specifications 28

4XZMF

installation 27, 29

see also Zone Relay Module 15

see also zone relay module 29

specifications 29

A

AC power 19

AC Power LED 40

AC power rating 12

AC power requirements 44

AC trouble delay 34

accessories 15

ACK

see also Acknowledge 10

Acknowledge 10, 13

Acknowledge button 38

alarm

piezo pulse rate 14

alarm relay 8, 9, 10, 14, 23

contact rating 12

Alarm Silence 10, 13

Alarm Silence LED 40

alarm verification 35, 36

timing graph 35

annunciator, remote

see also RZA-4XF 30

applications 10

audible Walktest 39

autoresettable supervisory 34

auto-silence 34

auxiliary power 23

B

backbox

dimensions 14, 17

mounting 17

battery 14, 19

precautions 19

rating 12

battery box 16

mounting 18

battery calculations 47

battery connector 8, 9

Battery Fault LED 41

BB-17F 18

see also battery box 16

buttons 13

see also control buttons 10

C

cabinet

dimensions 17, 18

mounting 17

see also backbox 14

CAC-4 20

installation 25

see also Class A Converter Module 9, 15

charger 14

charger capacity 12

Charger Fault LED 41

circuits 10

Class A 15, 20, 26

Class A Converter Module 9, 15

installation 25

Class B 10, 12, 14, 20

coding

NACs 34

combination circuit 10, 21

see also waterflow/tamper 34

combination waterflow/supervisory 10, 20, 21

requirements 21

wiring 21

compatibility

see also device compatibility 10

control buttons 10

controls 13

current

maximum system 12

nonresettable power 23

resettable power 23

see also system current 10

total output 22

current requirements for system 45, 46

D

description 10

device compatibility 10

Digital Alarm Communicator/Transmitter

see also 411 & 411UD 16

dimensions

backbox 14, 17

DIP switch options

see also programming 31

DIP switch settings 32

see also programming 31

disable

see also zone enable/disable 10

disable NAC 36

dress panel 10, 15

E

Earth Fault LED 41

earth ground 19

Index

enable
see also zone enable/disable 10

End-of-Line resistor
IDC 12, 20, 21
NAC 12, 22

F

fail-safe
trouble relay 23

fail-safe relay
see also trouble relay 14

features 10

fire alarm response 42

fire alarm restoral 42

Form-C 15, 29
see also relay 10, 14

freeze 20

freeze signal
see also smoke detector monitoring 10

G

Gentex synchronization 37

Ground Fault
disable 8, 9

I

I3 detectors 14, 20

IDC 9, 10, 12, 14, 20
alarm current 12
compatibility 20
End-of_Line resistor 21
End-of-Line resistor 12, 20
maximum loop resistance 12, 20
see also Initiating Device Circuit 8
short circuit current 12
standby current 12
wiring 20

indicators 13
see also LED 11

Initiating Device Circuit 8, 9, 10, 12, 14, 20
Class A 26

In-Line resistor
IDC combination circuit 21

installation 17
4XLMF 27
4XTMF 27, 28
4XZMF 27
CAC-4 25
Class A Converter Module 25
option modules 25, 27

J

J3 and J5
option module connectors 27

J4 and J6
option module connectors 27

JP1 jumper
placement supervision 27

JP2
placement supervision 27

L

Lamp Test 38

LED 11, 13
AC Power 11, 13, 40
Alarm Silence 11, 13
alarm silence 40
Battery Fault 11, 13
battery fault 41
Charger 11, 13
charger fault 41
Earth Fault 11, 13
earth fault 41
Fire Alarm 11, 13
main circuit board 8, 9
Maintenance 11, 13
NAC Disable 11, 13
NAC disable 40
NAC Fault 11, 13
NAC fault 40
Power Trouble 11, 13
power trouble 40
Supervisory 11, 13
System Trouble 11, 13
system trouble 40
Trouble 11, 13
Walktest 11, 13
walktest 40
Zone Disable 11, 13
zone disable 40
zone fire alarm 40
zone maintenance 41
zone supervisory 41
zone trouble 41
LED Interface Module 15
installation 27
see also 4XLMF 30

M

main circuit board
see also MS-2 8
see also MS-4 9
maintenance 20
piezo pulse rate 14
maintenance signal
see also smoke detector monitoring 10
modes of operation
see also normal and walktest 38
mounting
cabinet 17
MS-2 Main Circuit Board 8
MS-4 Main Circuit Board 9
municipal box 28
municipal box transmitter
see also 4XTMF 15

N

NAC 9, 10, 12, 14, 22
coding 34
current 22

Index

- disable 36
- End-of-Line resistor 12, 22
- maximum current 12
- nonsilenceable 36
- see also Notification Appliance Circuit 8
- wiring 22
- NAC Disable LED 40
- NAC Fault LED 40
- nonpower-limited wiring 24
- nonresettable power 9, 10, 12, 14, 23
 - current 23
 - maximum current 12
- nonsilenceable NAC 36
- normal mode 38
- Notification Appliance Circuit 8, 9, 10, 12, 14, 22
 - Class A 26
- O**
- operating instructions 38
- operation 41
- option modules 15
 - connector 9
 - connectors 27
 - installation 25, 27
 - placement supervision 27
- P**
- piezo 14
 - alarm 14
 - maintenance 14
 - see also sounder 11
 - supervisory 14
 - trouble 14
- polarity reversal circuit
 - see also 4XTMF 28
- power 12, 19, 23
 - maximum system 12
 - primary 19
 - secondary
 - see also battery 19
 - see also resettable and nonresettable power 9
- power supply calculations 44
- Power Trouble LED 40
- power-limited wiring 24
- programming 31, 32
 - chart 32
 - DIP switches 31
 - feature chart 32
 - supervisory 35
- programming DIP switches 31
- R**
- relay 8, 9, 10, 14, 15, 23, 29
 - contact rating 12, 23
- Remote Annunciator
 - see also RZA-4XF 15
- remote station service 28
- Reset 10
- Reset button 38
- resettable power 8, 9, 10, 12, 14, 23
 - current 23
 - maximum current 12
- reverse polarity circuit
 - see also 4XTMF 15
- RZA-4XF
 - see also Remote Annunciator 15
 - see also remote annunciator 30
 - wiring to RXLMF 30
- S**
- selective silence 34
- silence
 - selective 34
- Silence button 38
- silence inhibit 34
- silent walktest 40
- sounder 11, 14
- status LEDs 40
- strobe synchronization
 - see also synchronization 37
- Style B 12, 14, 20
 - see also Class B 10
- Style D 15, 20, 26
- Style Y 12, 14
 - see also Class B 10
- Style Z 15, 26
- supervision
 - option module placement 27
- supervisory
 - piezo pulse rate 14
 - see also programming supervisory 35, 36
- supervisory relay 9, 10, 14, 23
 - contact rating 12
- supervisory response 42
- supervisory restoral 42
- switch functions 38
- synchronization
 - Gentex 37
 - see also strobe synchronization 37
 - System Sensor 37
 - Wheelock 37
- system current 10
- system current calculations 45
- System Sensor synchronization 37
- System Trouble LED 40
- T**
- temporal coding 34
- transformer assembly 14
 - rating 14
- Transmitter Module 15
- transmitter module
 - see also 4XTMF 28
- trouble
 - piezo pulse rate 14
- trouble relay 8, 9, 10, 14, 23
 - contact rating 12
 - fail-safe 23
- trouble reminder 34

Index

trouble response 43

trouble restoral 43

U

UL

wiring requirements 24

V

verification

alarm timing graph 35

see also alarm verification 35

W

Walktest 10, 13

Walktest LED 40

Walktest Mode 38

Walktest mode 39

audible 39

exiting 40

silent 40

waterflow/tamper circuit 34

Wheelock synchronization 37

wiring

CAC-4 26

Class A Converter Module 26

Class A IDC 26

Class A NAC 26

combination waterflow/supervisory 21

IDC 20

NAC 22

nonpower-limited 24

power-limited 24

UL requirements 24

Z

Zone 1 20

Zone Disable LED 40

Zone Enable/Disable 10, 13

Zone Fire Alarm LED 40

Zone Maintenance LED 41

zone relay module 15

see also 4XZMF 29

Zone Supervisory LED 41

Zone Trouble LED 41

Notes

Notes

Limited Warranty

The manufacturer warrants its products to be free from defects in materials and workmanship for eighteen (18) months from the date of manufacture, under normal use and service. Products are date-stamped at time of manufacture. The sole and exclusive obligation of the manufacturer is to repair or replace, at its option, free of charge for parts and labor, any part which is defective in materials or workmanship under normal use and service. For products not under the manufacturer's date-stamp control, the warranty is eighteen (18) months from date of original purchase by the manufacturer's distributor unless the installation instructions or catalog sets forth a shorter period, in which case the shorter period shall apply. This warranty is void if the product is altered, repaired, or serviced by anyone other than the manufacturer or its authorized distributors, or if there is a failure to maintain the products and systems in which they operate in a proper and workable manner. In case of defect, secure a Return Material Authorization form from our customer service department. Return product, transportation prepaid, to the manufacturer.

This writing constitutes the only warranty made by this manufacturer with respect to its products. The manufacturer does not represent that its products will prevent any loss by fire or otherwise, or that its products will in all cases provide the protection for which they are installed or intended. Buyer acknowledges that the manufacturer is not an insurer and assumes no risk for loss or damages or the cost of any inconvenience, transportation, damage, misuse, abuse, accident, or similar incident.

THE MANUFACTURER GIVES NO WARRANTY, EXPRESSED OR IMPLIED, OF MERCHANTABILITY, FITNESS FOR ANY PARTICULAR PURPOSE, OR OTHERWISE WHICH EXTEND BEYOND THE DESCRIPTION ON THE FACE HEREOF. UNDER NO CIRCUMSTANCES SHALL THE MANUFACTURER BE LIABLE FOR ANY LOSS OF OR DAMAGE TO PROPERTY, DIRECT, INCIDENTAL, OR CONSEQUENTIAL, ARISING OUT OF THE USE OF, OR INABILITY TO USE THE MANUFACTURER'S PRODUCTS. FURTHERMORE, THE MANUFACTURER SHALL NOT BE LIABLE FOR ANY PERSONAL INJURY OR DEATH WHICH MAY ARISE IN THE COURSE OF, OR AS A RESULT OF, PERSONAL, COMMERCIAL, OR INDUSTRIAL USE OF ITS PRODUCTS.

This warranty replaces all previous warranties and is the only warranty made by the manufacturer. No increase or alteration, written or verbal, of the obligation of this warranty is authorized.



World Headquarters

One Fire-Lite Place, Northford, CT 06472-1653 USA

203-484-7161 • Fax 203-484-7118

www.firelite.com

ISO 9001
CERTIFIED
ENGINEERING & MANUFACTURING